



3-Phase 3-Wire AC Voltage Sensor CYVS13-xnS3

The **CYVS13-xnS3** AC Voltage Sensor/Transducer works according electro-magnetic induction and is designed for applications to measurement and monitoring of 3-Phase 3-Wire AC voltage. The output signals (DC voltage or current) of this transducer are proportional to the average effective value (RMS) of input AC voltages. They are suitable for general applications such as fixed frequency voltage supplies and sinusoid voltages etc.

Specifications

Rated input voltage range	50V, 75V, 100V, 200V, 250V, 300V, 380V, 400V, 500V
Frequency of input voltage	Typ. 50Hz, 60Hz, max. 5kHz
Output signal	0-5VDC, 0-20 mA, 4-20 mA, 0-10V DC
Output load	≥2kΩ for voltage output, ≤250Ω for current output
Power supply	+12V, +15V, +24V DC
Measuring accuracy	0.5%
Isolation	between input, output and power supply
Input resistance	>1kΩ/V
Load resistance	≥2kΩ for voltage output, ≤250Ω for current output
Isolation withstanding voltage	2.5 kV DC, 1min, leakage current 1mA
Operating temperature	-10°C ~ +60°C
Storage temperature	-25°C ~ + 70°C
Relative humidity	10% ~ 90%
Response time	≤250ms
Overload capacity	2 times
Quiescent power consumption	400mW – 500mW
Mounting	Din rail
Case style	S3 without aperture

Definition of Part Number:

CYVS13	-	x	n	S3	-	0.5	-	m
(1)		(2)	(3)	(4)		(5)		(6)

(1)	(2)	(3)	(4)	(5)	(6)
Series name	Output signal	Power supply	Case style	Accuracy class	Input voltage range (m)
CYVS13	x=1: 0-5VAC x=3: 0-5V DC x=4: 0-20mA DC x=5: 4-20mA DC x=8: 0-10V DC	n=2: +12V DC n=3: +15V DC n=4: +24V DC	S3	0.5%	50V, 75V, 100V, 200V, 250V, 300V, 380V, 400V, 500V

Example 1: CYVS13-32S3-0.5-380V, 3-Phase 3-Wire AC voltage sensor with
 Output signal: 0-5V DC
 Power supply: +12V DC
 Rated input voltage: 380V AC/RMS



Example 2: CYVS13-54S3-0.5-380V, 3-Phase 3-Wire AC voltage sensor with
Output signal: 4-20mA DC
Power supply: +24V DC
Rated input voltage: 380V AC/RMS

DIMENSIONS (mm)

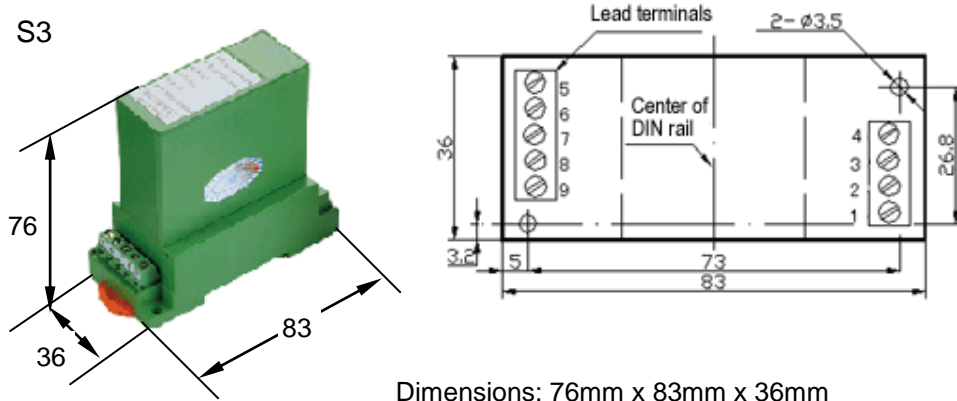

CONNECTIONS

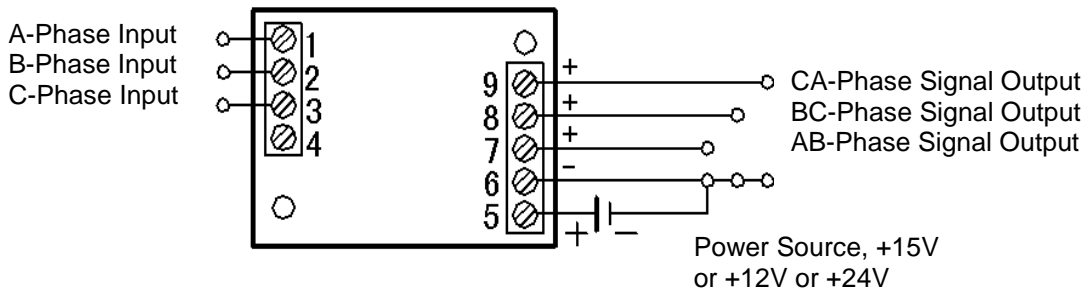

Wiring of Terminals for voltage output:

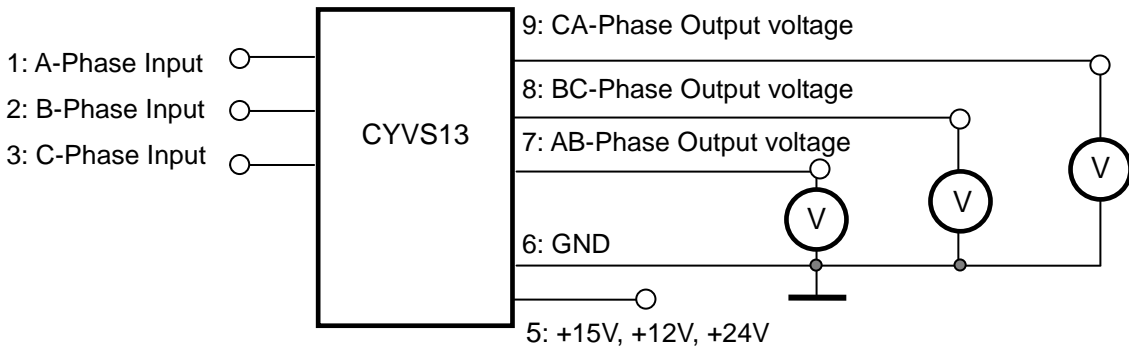

5: +15V, +12V, +24V Power Supply

6: GND

7, 8, 9: Voltage Output

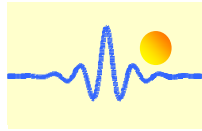

Wiring of Terminals for Current Output:

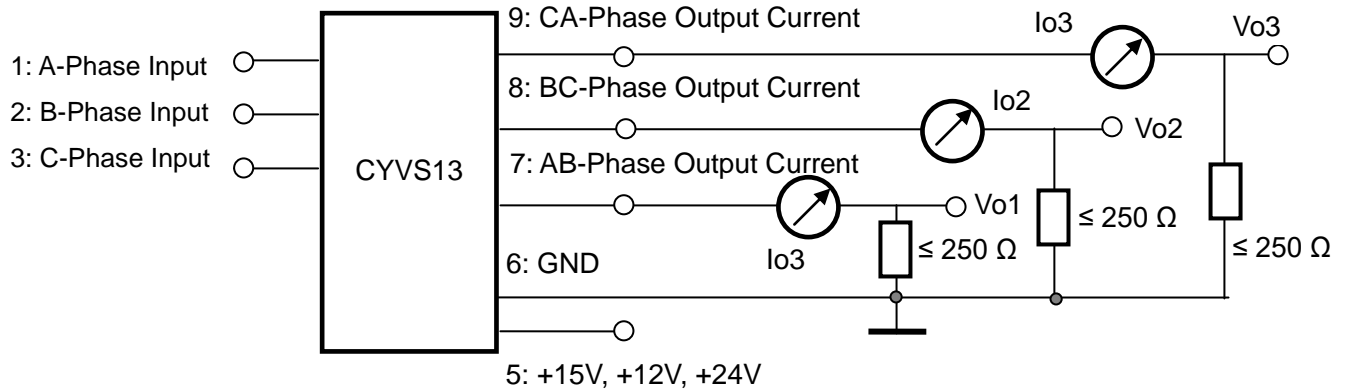

5: +15V, +12V, +24V Power Supply

6: GND

7, 8, 9: Current Output

Relation between Input and Output (for $R_m=250 \Omega$):

Sensor CYVS13-54S3-0.5-380V		
Voltage Input (V)	Output current I_o (mA)	Output voltage V_o (V)
0	4	1
95	8	2
190	12	3
285	16	4
380	20	5

Application:

- Harmonic voltages
- Chopped waveform drivers
- Quickly varying voltage supplies
- Phase fired controlled devices

Notice:

1. There is no polarity requirement for the input current connection.
2. The output signal and the power source are common grounded at terminal 6.
3. The output at terminal 7 corresponds to the line voltage V_{AB} , the output at terminal 8 is line voltage V_{BC} , and the output at terminal 8 presents line voltage V_{CA}