

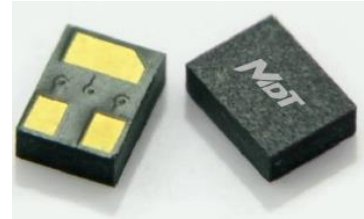

## CYS1345 High Sensitive Omnipolar TMR Switch IC

CYS1345 is a digital omnipolar magnetic switch that integrates TMR and CMOS technology in order to provide a magnetically triggered digital switch with high sensitivity, high speed, and ultra-low power consumption. It is designed for use in applications that are both power-critical and performance-demanding. It contains a push-pull half-bridge TMR magnetic sensor and CMOS signal processing circuitry within the same package, including an on-chip TMR voltage generator for precise magnetic sensing, a TMR voltage amplifier and comparator with a Schmitt trigger to provide switching hysteresis for noise rejection, and CMOS push-pull output. An internal band gap regulator is used to provide a temperature compensated supply voltage for internal circuits, permitting a wide range of supply voltages. The CYS1345 draws only 1.5 $\mu$ A resulting in ultra-low power operation. It has fast response, accurate switching points, excellent thermal stability, and immunity to stray field interference. It is available in the LGA2x1.5x0.63 -3L package.



### Features

- Bipolar latching operation
- Low power consumption (<1.5 $\mu$ A)
- Z-axis sensing direction compatible with Hall Effect Switch ICs
- Low switch points for high sensitivity
- Excellent thermal stability

### Typical Applications

- Water, gas and heat meters
- High Sensitive Non-contact Switch
- DC Brushless Motor
- DC Brushless Fan
- Position and speed sensing

### Functional Block Diagram

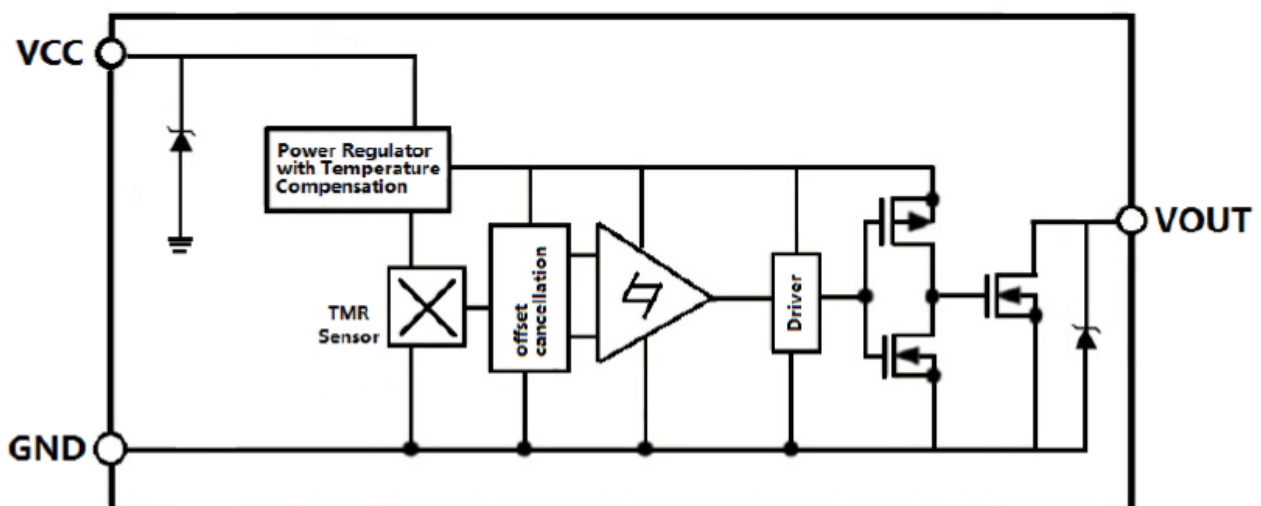



## Absolute Maximum Ratings

Parameter	Symbol	Limit	Unit
Supply Voltage	$V_{CC}$	7	V
Reverse Supply Voltage	$V_{RCC}$	0.3	V
Output Current	$I_{OUTSINK}$	20	mA
Magnetic Flux Density	B	2800	G
ESD level(HBM)	$V_{ESD}$	2	kV
Operating Ambient Temperature	$T_A$	-40 ~ 125	°C
Storage Temperature	$T_{stg}$	-50 ~ 150	°C

## Electrical Characteristics ( $V_{CC}=3.0V$ , $T_A=25^\circ C$ )

Parameter	Symbol	Conditions	Min	Typ.	Max	Unit
Supply Voltage	$V_{CC}$	Operating	1.5	3.0	5.5	V
Output Stress Voltage	$V_{stress}$				5.5	V
Output leak Current	$I_{leak}$	OUT=H, $V_{CC}=3V$ , $V_{out}=3V$			1	$\mu A$
Output Resistance of Turn off	$R_{off}$	OUT=H		10		$M\Omega$
Output Low Voltage	VOL	OUT=L, $V_{CC}=3V$ , $I_{sink}=10mA$	0		0.1	V
Output Resistance of Turn on	$R_{on}$	OUT=L			10	$\Omega$
Supply Current	$I_{CC}$	Output Open		1.5		$\mu A$
Response Frequency	F			1000		KHz

**Note:** a 1k $\Omega$  pull-up resistor is connected between  $V_{CC}$  and  $V_{OUT}$ , and a 100nF capacitor is connected between  $V_{CC}$  and GND during all tests in the above table.

## Magnetic Characteristics ( $V_{CC} = 3.0V$ , $T_A = 25^\circ C$ )

Parameters	Symbol	Min	Typ.	Max	Unit
Operate Point	$B_{OPS}$		50		G
	$B_{OPN}$		-50		G
Release Point	$B_{RPS}$		45		G
	$B_{RPN}$		-45		G
Hysteresis	$B_H$		5		G

## Voltage Characteristics

### Voltage Performance ( $T_A=25^\circ C$ )

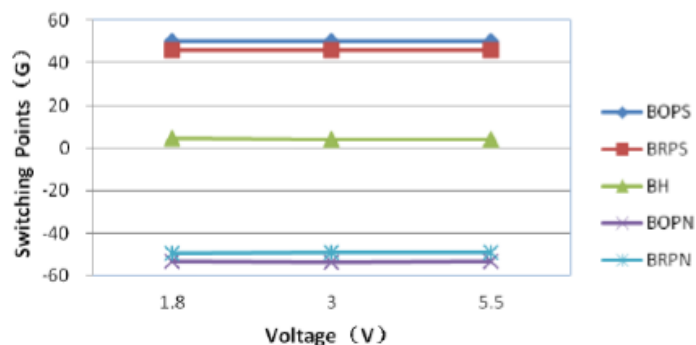

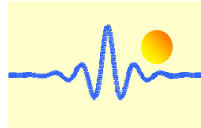

## Output Behavior vs. Magnetic Pole

Parameter	Test Conditions	Output
South Pole	$B > B_{OPS}$	Low (On)
	$0 < B < B_{RPS}$	High (Off)
North Pole	$B < B_{OPN}$	Low (Off)
	$0 > B > B_{RPN}$	High (Off)

**Note:** when power is turned on under zero magnetic field, the output is “High”.

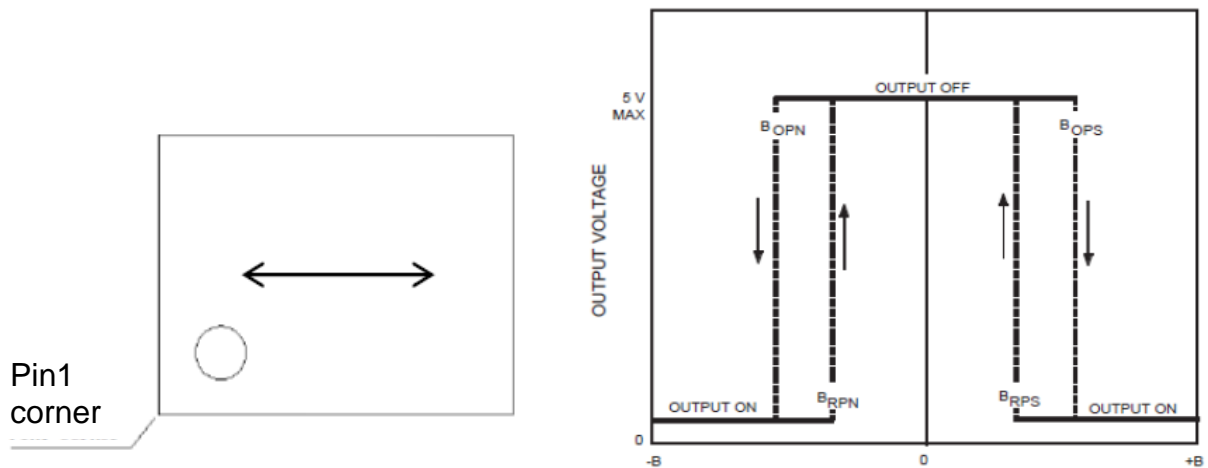

Sensing direction of magnetic field

Magnetic Flux

## Pin Configuration



Top view

Bottom view

Pin Name	Pin No. LGA2x1.5-3L	Pin Function
VCC	3	Supply Voltage
GND	1	Ground
VOUT	2	Output



## Application Information

The output of the CYS1345 switches low (turns on) when a magnetic field to the sensing axis exceeds the operate point threshold,  $B_{OP}$ . When the magnetic field is reduced below the release point,  $B_{RP}$ , the device output switches high (turns off). The difference between the  $B_{OP}$  and  $B_{RP}$  is the hysteresis  $B_H$  of the device.

It is strongly recommended that an external bypass capacitor be connected in close proximity to the device between the supply and ground to reduce noise. The typical value of the external capacitor is  $0.1\mu\text{F}$ .  $1\text{k}\Omega$  is a pull-up resistor.

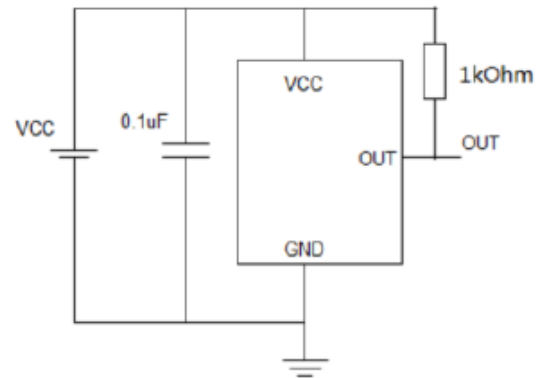

## TMR Sensor Position (unit: mm)

### LGA3L

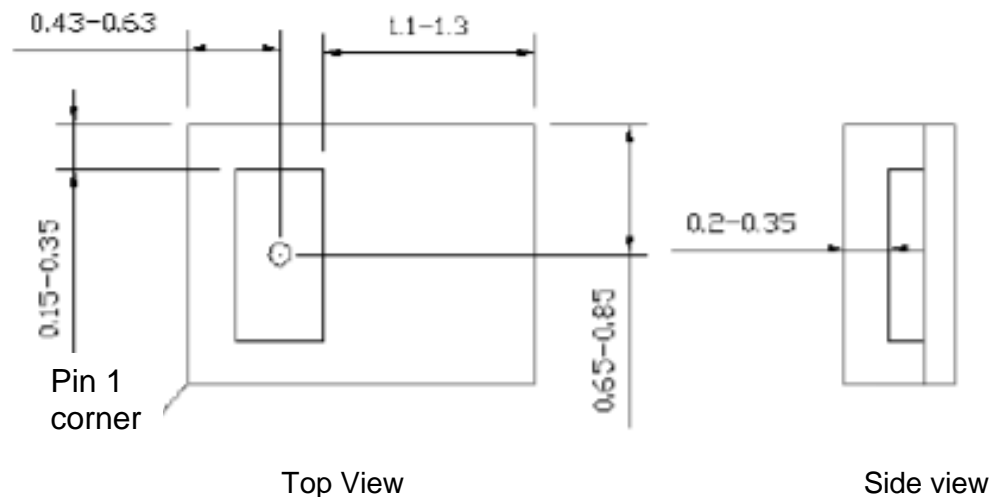

## Part number

Part number	Response Frequency	Operating Temperature	Package
CYS1345G	1000Hz	-40°C ~ 125°C	LGA3L

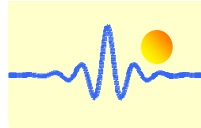

## Package Information

### LGA3L Package Drawing

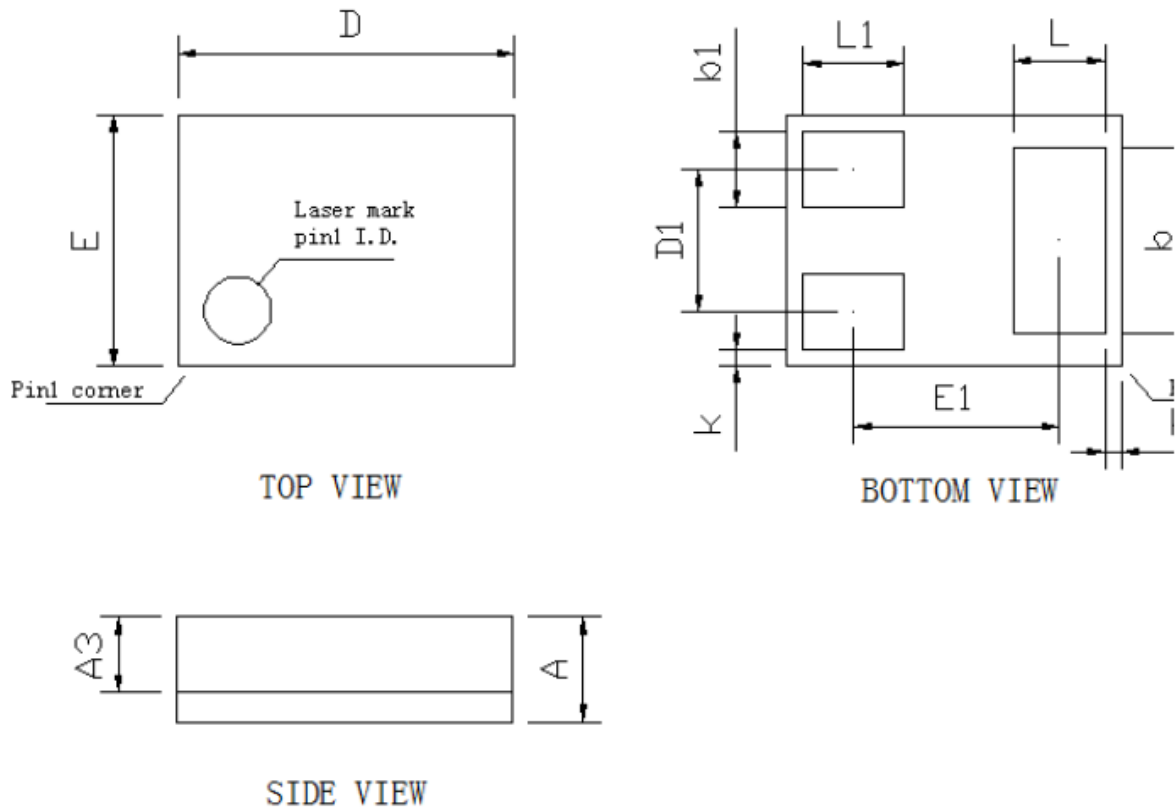

Symbol	Dimensions in mm			Dimensions in inches		
	min	nom	max	min	nom	max
<b>A</b>	-	0.63	0.70	-	0.025	0.028
<b>A3</b>	0.45 BSC			0.018 REF		
<b>D</b>	1.90	2.00	2.10	0.075	0.079	0.083
<b>D1</b>	0.85 BSC			0.033 REF		
<b>E</b>	1.40	1.50	1.60	0.055	0.059	0.063
<b>E1</b>	1.23 BSC			0.048 REF		
<b>L</b>	0.55 BSC			0.022 REF		
<b>L1</b>	0.60 BSC			0.024 REF		
<b>b</b>	1.10 BSC			0.043 REF		
<b>b1</b>	0.45 BSC			0.018 REF		
<b>h</b>	0.10 REF			0.004 REF		
<b>k</b>	0.10 REF			0.004 REF		