



## CYS1308 High Sensitive Omnipolar TMR Switch IC

CYS1308 is a digital omnipolar magnetic switch that integrates TMR and CMOS technology in order to provide a magnetically triggered digital switch with high sensitivity, high speed, and ultra-low power consumption. It is designed for use in applications that are both power-critical and performance-demanding. It contains a push-pull half-bridge TMR magnetic sensor and CMOS signal processing circuitry within the same package, including an on-chip TMR voltage generator for precise magnetic sensing, a TMR voltage amplifier and comparator plus a Schmitt trigger to provide switching hysteresis for noise rejection, and CMOS push-pull output. An internal band gap regulator is used to provide a temperature compensated supply voltage for internal circuits, permitting a wide range of supply voltages. The CYS1308 draws only 1.5 $\mu$ A resulting in ultra-low power operation. It has fast response, accurate switching points, excellent thermal stability, and immunity to stray field interference. It is available in the SOT23-3 package and the TO-92S package



### Features

- Operation with North or South Pole
- Low power consumption (<1.5 $\mu$ A)
- High tolerance to external magnetic field interference
- Low switch points for high sensitivity
- Excellent thermal stability

### Typical Applications

- Water, gas and heat meters
- Proximity Switches
- DC Brushless Motor
- DC Brushless Fan
- Position and speed sensing

### Functional Block Diagram

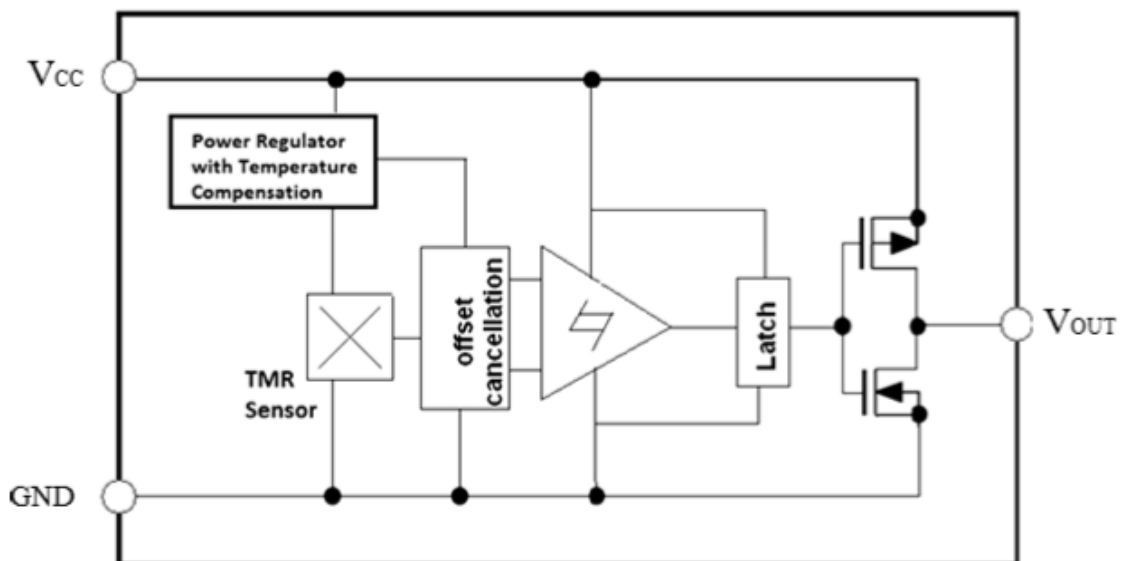



## Absolute Maximum Ratings

Parameter	Symbol	Limit	Unit
Supply Voltage	$V_{CC}$	7	V
Reverse Supply Voltage	$V_{RCC}$	0.3	V
Output Current	$I_{OUTSINK}$	9	mA
Magnetic Flux Density	B	2800	G
ESD level (HBM)	$V_{ESD}$	2	kV
Operating Ambient Temperature	$T_A$	-40 ~ 125	°C
Storage Temperature	$T_{stg}$	-50 ~ 150	°C

## Electrical Characteristics ( $V_{CC}=3.0V$ , $T_A=25^\circ C$ )

Parameter	Symbol	Conditions	Min	Typ.	Max	Unit
Supply Voltage	$V_{CC}$	Operating	1.8	3.0	5.5	V
Output High Voltage	$V_{OH}$		$V_{CC}-0.3$		$V_{CC}$	V
Output Low Voltage	$V_{OL}$		0		0.2	V
Supply Current	$I_{CC}$	Output open		1.5		$\mu A$
Response Frequency	F			1000		Hz

**Note:** a 100nF capacitor is connected between  $V_{CC}$  and GND during all tests in the above table.

## Magnetic Characteristics ( $V_{CC} = 3.0V$ , $T_A = 25^\circ C$ )

Parameters	Symbol	Min	Typ.	Max	Unit
Operate Point	$B_{OPS}$		5		G
	$B_{OPN}$		-5		G
Release Point	$B_{RPS}$		4		G
	$B_{RPN}$		-4		G
Hysteresis	$B_H$		1		G

**Note:** a 100nF capacitor is connected between  $V_{CC}$  and GND during all tests in the above table.

## Voltage Characteristics

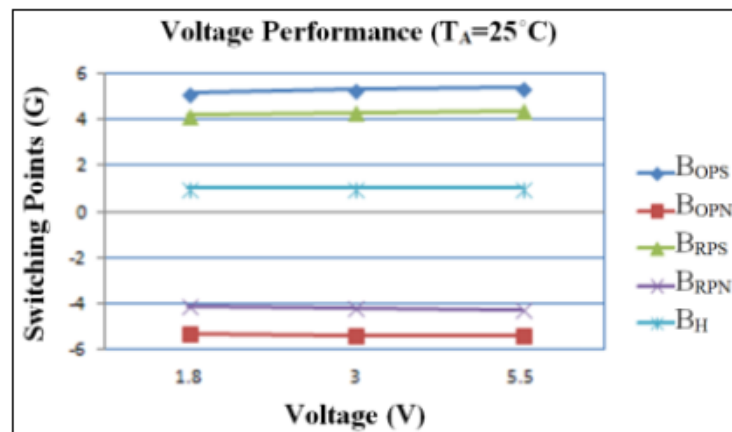



## Output Behavior vs. Magnetic Pole

Parameter	Test Conditions	Output
South Pole	$B > B_{OPS}$	Low (On)
	$0 < B < B_{RPS}$	High (Off)
North Pole	$B < B_{OPN}$	Low (Off)
	$0 > B > B_{RPN}$	High (On)

**Note:** when power is turned on under zero magnetic field, the output is "High".

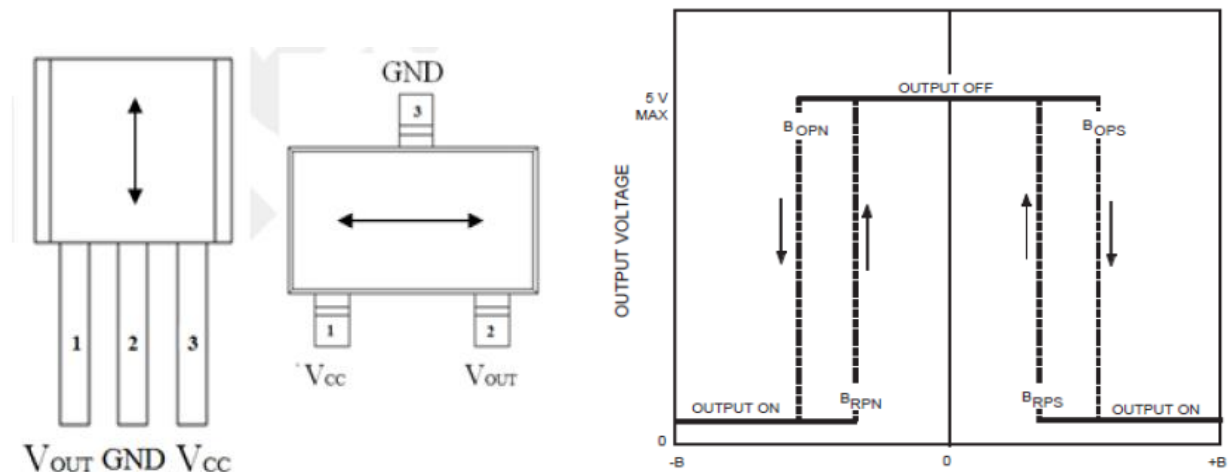

Sensing direction of magnetic field

Magnetic Flux

## Pin Configuration

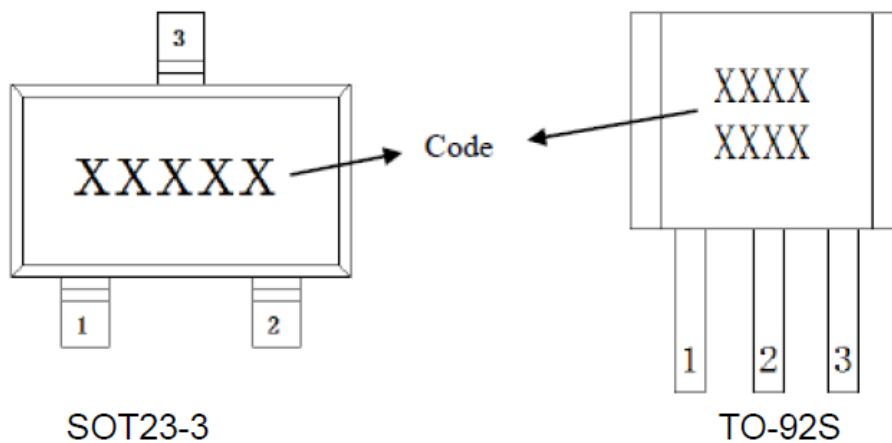

Pin Name	Pin No.		Pin Function
	TO-92S	SOT23-3	
VCC	3	1	Supply Voltage
GND	2	3	Ground
VOUT	1	2	Output



## Application Information

The output of the CYS1308 switches low (turns on) when a magnetic field to the sensing axis exceeds the operate point threshold,  $B_{OP}$ . When the magnetic field is reduced below the release point,  $B_{RP}$ , the device output switches high (turns off). The difference between the  $B_{OP}$  and  $B_{RP}$  is the hysteresis  $BH$  of the device.

It is strongly recommended that an external bypass capacitor be connected in close proximity to the device between the supply and ground to reduce noise. The typical value of the external capacitor is  $0.1\mu F$ .

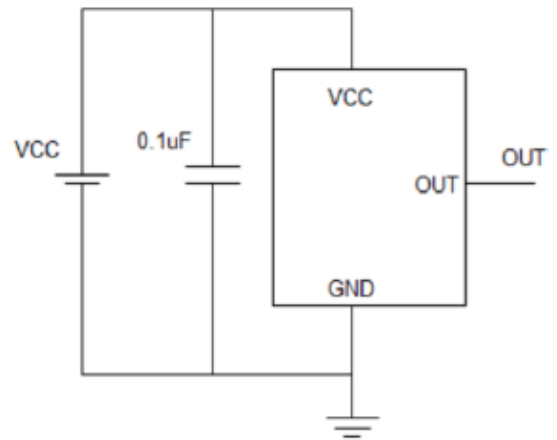

## TMR Sensor Position (unit: mm)

### SOT23-3

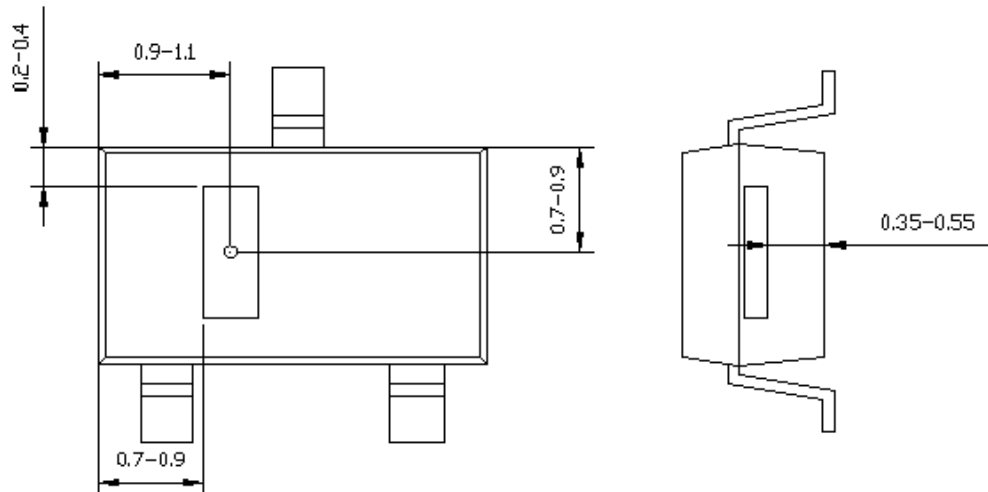

### TO-92S

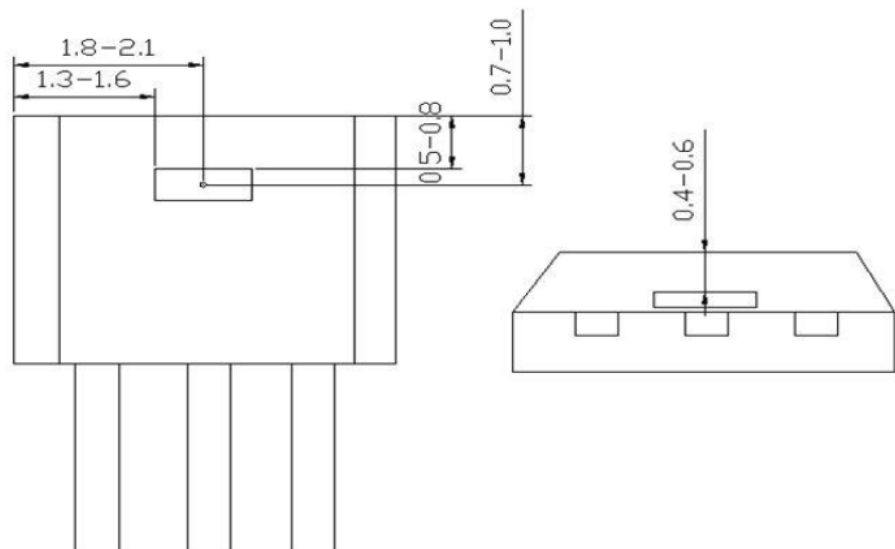

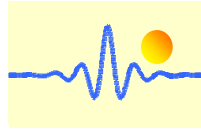

## Package Information

### SOT23-3 Package Drawing

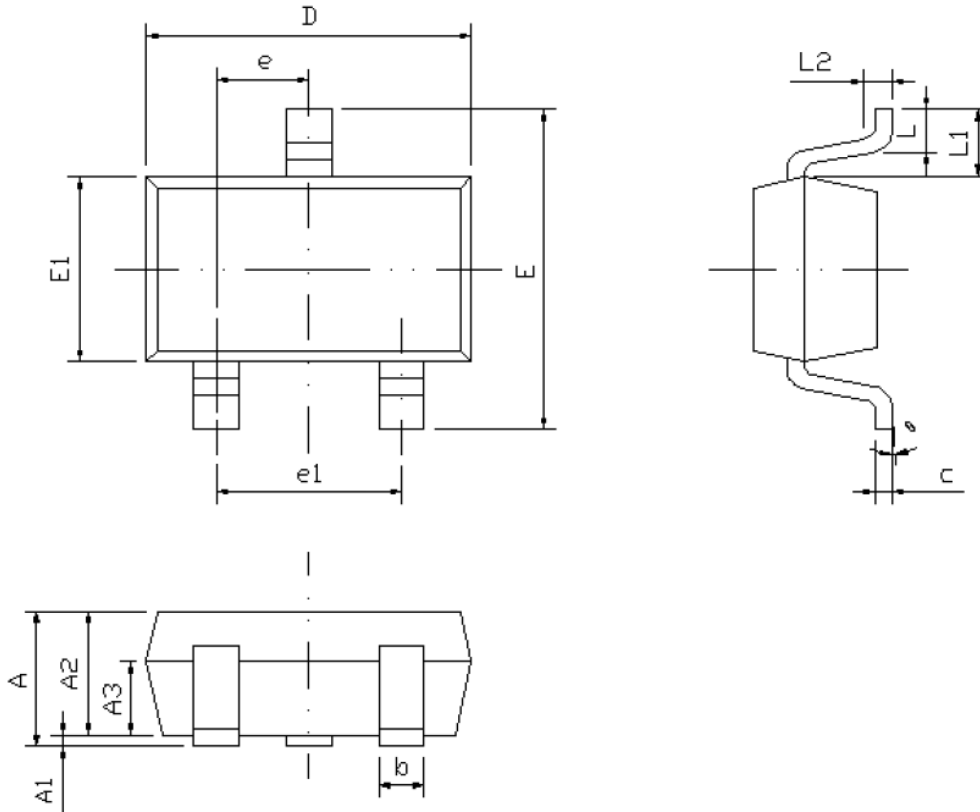

Symbol	Dimensions in mm			Dimensions in inches		
	min	nom	max	min	nom	max
<b>A</b>	-	-	1.45	-	-	0.057
<b>A1</b>	0.00	-	0.15	0.000	-	0.006
<b>A2</b>	0.90	1.10	1.30	0.035	0.043	0.051
<b>A3</b>	0.60	0.65	0.70	0.024	0.026	0.028
<b>b</b>	0.39	-	0.49	0.015	-	0.019
<b>c</b>	0.12	-	0.19	0.005	-	0.007
<b>D</b>	2.85	2.95	3.05	0.112	0.116	0.120
<b>E</b>	2.60	2.80	3.00	0.102	0.110	0.118
<b>E1</b>	1.55	1.65	1.75	0.061	0.065	0.069
<b>e</b>	0.85	0.95	1.05	0.033	0.037	0.041
<b>e1</b>	1.80	1.90	2.00	0.071	0.075	0.079
<b>L</b>	0.35	0.45	0.60	0.014	0.018	0.024
<b>L1</b>	0.59REF			0.023REF		
<b>L2</b>	0.25BSC			0.010BSC		
<b>θ</b>	0°	-	8°	0°	-	8°

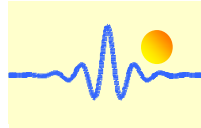

### TO-92S Package Drawing

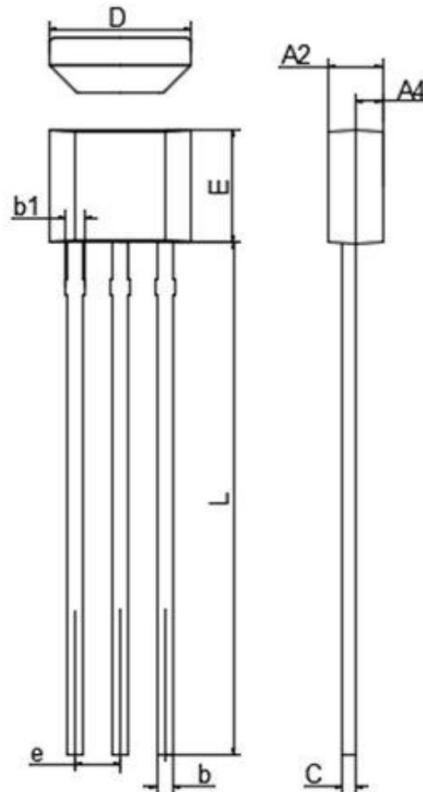

Symbol	Dimensions in mm			Dimensions in inches		
	min	nom	max	min	nom	max
<b>A2</b>	1.40	1.50	1.60	0.055	0.059	0.063
<b>A4</b>	0.75 TYP			0.030 TYP		
<b>b</b>	0.34	0.39	0.42	0.013	0.015	0.017
<b>b1</b>	0.40	0.46	0.50	0.016	0.018	0.020
<b>C</b>	0.37	0.40	0.42	0.015	0.016	0.017
<b>D</b>	3.90	4.10	4.20	0.154	0.161	0.165
<b>E</b>	2.90	3.05	3.30	0.114	0.120	0.130
<b>e</b>	1.27 TYP			0.050 TYP		
<b>L</b>	14.0	14.5	15.0	0.551	0.571	0.590

### Part number

Part number	Response Frequency	Operating Temperature	Package
CYS1308S	1000Hz	-40°C ~ 125°C	SOT23-3
CYS1308T	1000Hz	-40°C ~ 125°C	TO-92S