

TMR Magnetic Field Sensor CYMR2104

The CYMR2104 linear sensor utilizes a unique push-pull Wheatstone bridge composed of four unshielded TMR sensor elements. The unique bridge design provides a high sensitivity differential output that is linearly proportional to a magnetic field applied parallel to the surface of the sensor package, and it provides superior temperature compensation of the output. The CYMR2104 is available in two packages: **SOP8** 6x5x1.5mm (P/N:CYMR2104P), or **DFN8** 3x3x0.75mm (P/N:CYMR2104D).

Features and Benefits

- Tunneling Magnetoresistance (TMR) Technology
- High Sensitivity
- Large Dynamic Range
- Very Low Power Consumption
- Excellent Thermal Stability
- Very Low Hysteresis
- Compatible with Wide Range of Supply Voltages



SOP8

Applications

- Magnetic Field Sensing
- Current Sensors
- Industrial Flow Meters
- Displacement Sensing
- Rotary Position Sensors



DFN8

Transfer Curve

The following figure shows the response of the CYMR2104 to an applied magnetic field in the range of ± 80 Oe (left) and ± 200 Oe (right) when the CYMR2104 is biased at 1V. At low fields the CYMR2104 response is highly linear, and it is not harmed when the sensor is driven into saturation.

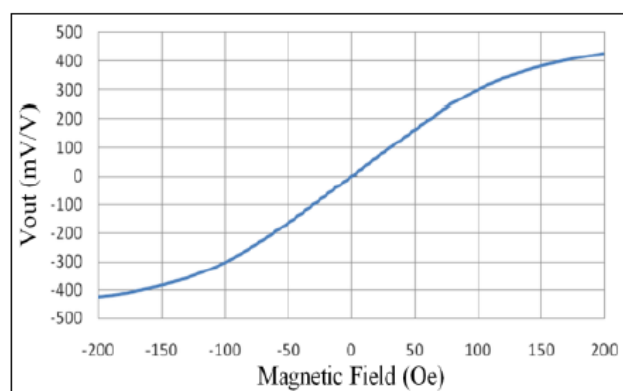
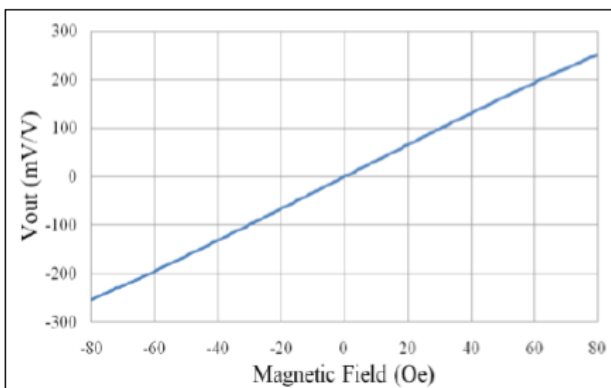

Oe (Oersted) = 1 Gauss in air = 0.1 millitesla = 79.8 A/m.

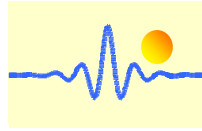

Absolute Maximum Ratings

Parameter	Symbol	Limit	Unit
Supply Voltage	V_{CC}	7	V
Reverse Supply Voltage	V_{RCC}	-7	V
Max Exposed Field	H_E	4000	Oe
ESD Voltage	V_{ESD}	4000	V
Operating Temperature	T_A	-40~125	°C
Storage Temperature	T_{stg}	-50 ~150	°C

Specification ($V_{CC}=1.0V, T_A=25^\circ C, \text{Differential Output}$)

Parameter	Symbol	Conditions	Min	Typ	Max	Unit
Supply Voltage	V_{CC}	Operating		1	7	V
Supply Current	I_{CC}	Output Open		33		μA
Resistance(SOP8)	R			30		k Ω
Sensitivity	S	Fit @ $\pm 80Oe$		3.1		mV/V/Oe
Saturation Field	H_{sat}			± 150		Oe
No-linearity	NL	Fit @ $\pm 80Oe$		1.5		%FS
Offset voltage	V_{os}		-8		8	mV/V
Hysteresis	Hys	Fit @ $\pm 80Oe$		0.5		Oe
Temperature Coefficient of resistance	TCR	H=0		-600		ppm/°C
Temperature Coefficient of Sensitivity	TCS			-300		ppm/°C

Pin Configuration

(Arrow indicates direction of applied field that generates a positive output voltage after a SET pulse.)

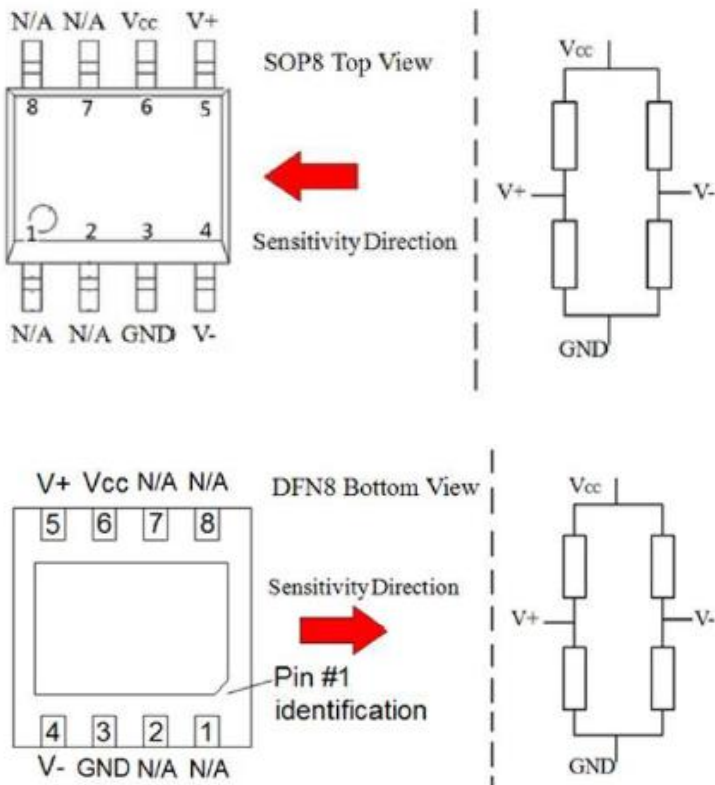

Pin No.	Pin Name	Pin function
1,2,7,8	N/A	Not connected
3	GND	Ground
4	V-	Analog Differential Output 2
5	V+	Analog Differential Output 1
6	Vcc	Supply Voltage

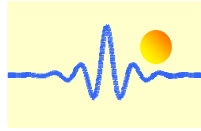

Package Information

SOP8 package drawing

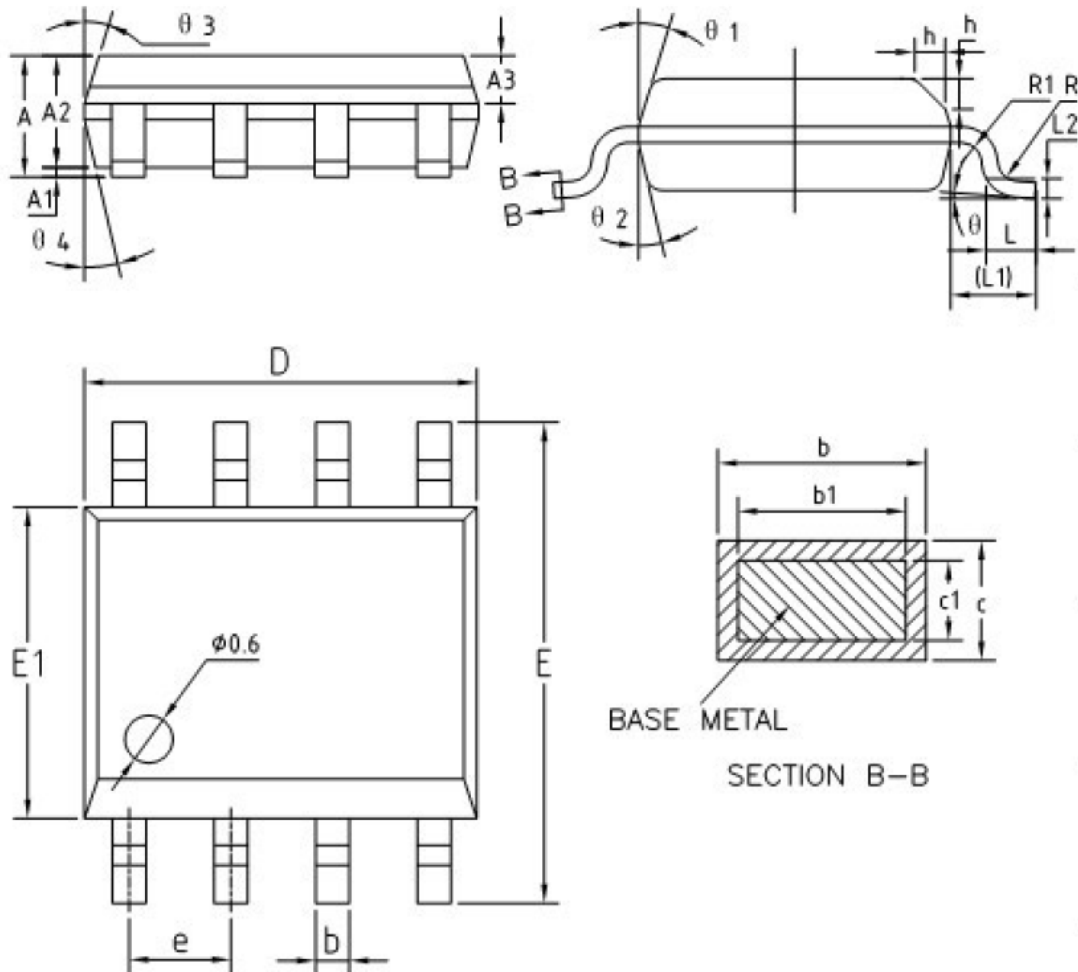

Common Dimensions (in mm)

Symbol	Min.	Typ.	Max.	Symbol	Min.	Typ.	Max.
A	1.35	1.55	1.75	A1	0.10	0.15	0.25
A2	1.25	1.40	1.65	A3	0.50	0.60	0.70
b	0.38	0.45	0.51	b1	0.37	0.42	0.47
c	0.18	0.22	0.25	c1	0.17	0.20	0.23
D	4.80	4.90	5.00	E	5.80	6.00	6.20
E1	3.80	3.90	4.00	e	1.17	1.27	1.37
L	0.45	0.60	0.80	L1	1.04 REF		
L2	0.25 BSC			R	0.07	-	-
R1	0.07	-	-	h	0.30	0.40	0.50
θ	0°	4°	8°	θ1	15°	17°	19°
θ2	11°	13°	15°	θ3	15°	17°	19°
θ4	11°	13°	15°				

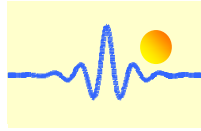

DFN8 package drawing

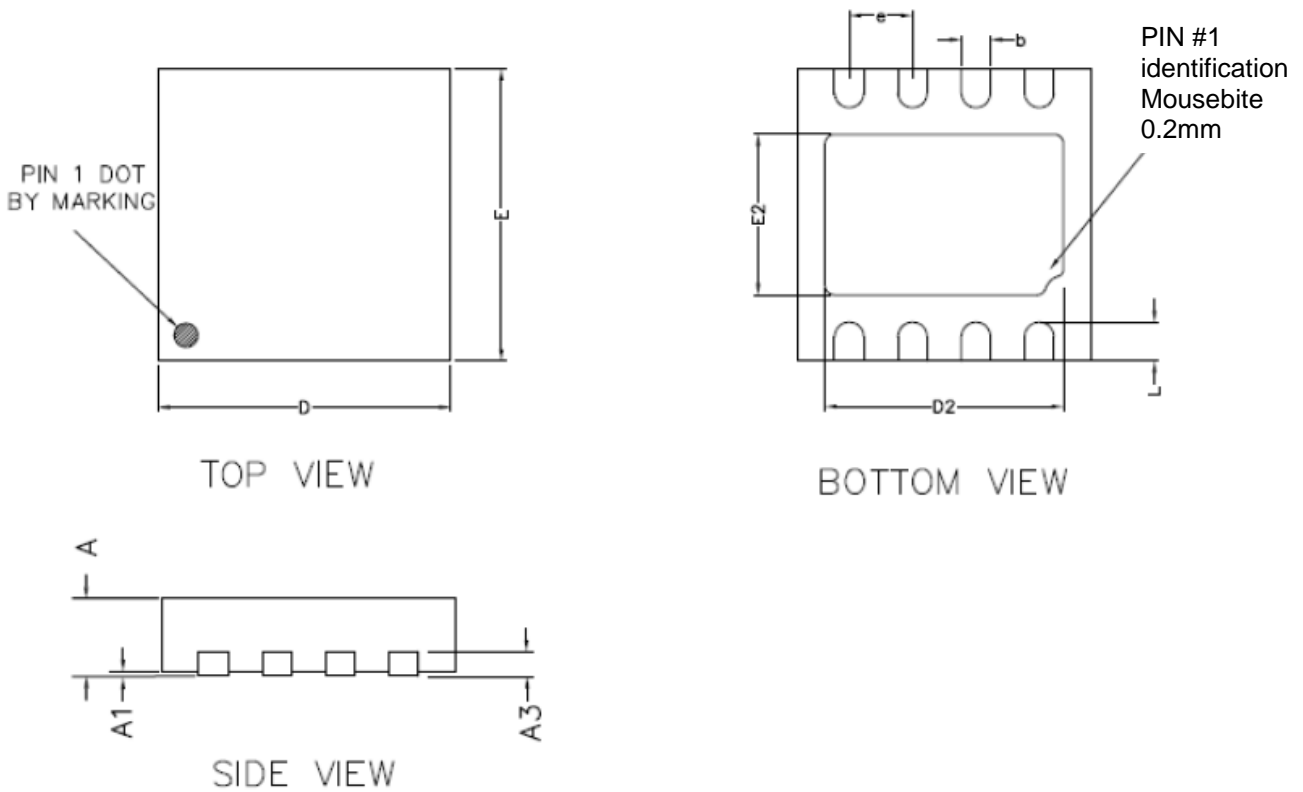

Common Demensions (in mm)

Symbol	Min.	Typ.	Max.
A	0.70	0.75	0.80
A1	0.00	-	0.05
A3	0.20 REF		
D	2.95	3.00	3.05
E	2.95	3.00	3.05
b	0.25	0.30	0.35
L	0.30	0.40	0.50
D2	2.30	2.45	2.55
E2	1.50	1.65	1.75
e	0.65 BSC		

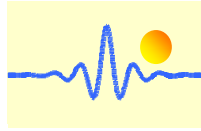

TMR Sensor Position

Top view and side view (unit: mm)

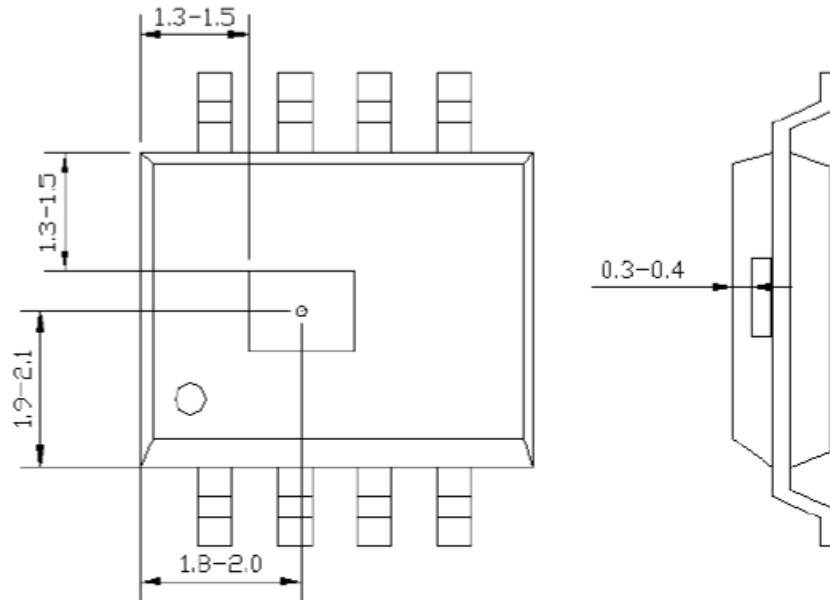

SOP8 Package

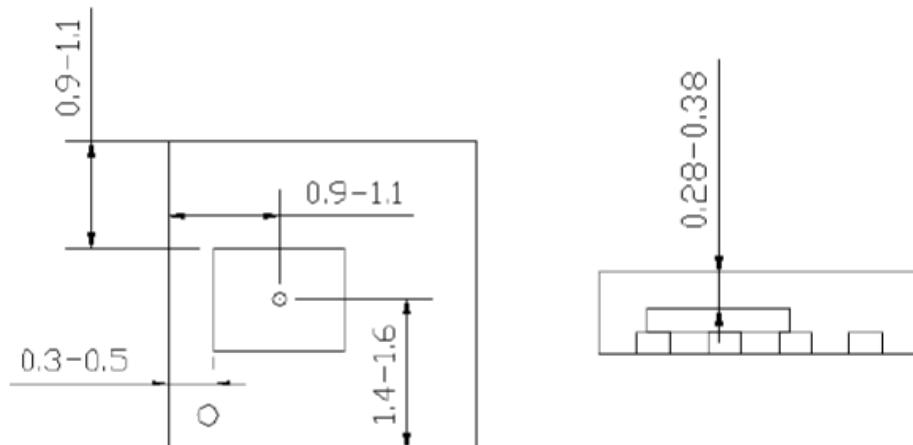

DFN8 Package