

AC Current Sensor CYCS11-xnM20B

This current sensor is based on magnetic modulation and compensation principle, and can be used for measurement of small AC current and leakage current, current difference between two or more conductors.

Product Characteristics:

- Application of Computer Aided Ageing Technology
- 100% Ageing Processing and Thermal Drift Test under high operating temperature in order to guarantee the long term stability of the sensors
- Custom makeable according to individual requirements
- Various current and voltage outputs are selectable
- Power supply options: $\pm 12\text{VDC}$ and $\pm 15\text{VDC}$, single power supply is possible.
- Sensors with window for contactless measurements

Applications:

- Isolation Monitoring of AC power systems and cable selection systems,
- Measurements of small AC currents and leakage currents etc.

Electrical Data

Measuring range M	10mA ~ 5A AC
Linearity range	1.2 x M (measuring range)
Nominal output signals	0-5VDC, tracing voltage -5V~+5V AC
Supply voltage	$\pm 12\text{VDC}$, $\pm 15\text{VDC}$
Current consumption	12mA + output current
Galvanic isolation	2KV RMS/50Hz/min
Measuring resistance for current output	$\leq 250\Omega$

Accuracy and Dynamic Performances

Thermal drift of offset current	Typ. 100; max. 250	ppm/°C
Response time	≤ 120	ms
Accuracy	± 1.0	%
Linearity	≤ 1.0	%FS

General Data

Operating temperature	-10 ~ +70	°C
Storage temperature	-40 ~ +70	°C
Window size	$\Phi 20$	mm
Case dimensions H x L x W	81 x 87.5 x 25	mm

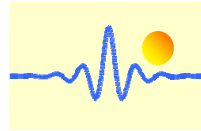

Definition of Part number:

CYCS11	-	x	n	M20B	-	1.0	-	m
(1)		(2)	(3)	(4)		(5)		(6)

(1)	(2)	(3)	(4)	(5)	(6)
Series name	Output signal	Power supply	Case style	Accuracy	Rated Input current (m)
CYCS11	x=1: tracing 5VAC x=3: 0-5V DC	n=5: ±12V DC n=6: ±15V DC	M20B With aperture Ø20mm	1.0%	m = 10mA, 20mA, 50mA,100mA,200mA, 500mA, 1A, 2A, 5A

Example 1: CYCS11-36M20B-1.0-10mA, AC Current sensor with
Output signal: 0-5V DC
Power supply: ±15V DC
Rated input current: 0-10mA AC

Example 2: CYCS11-15M20B-1.0-10mA, AC Current sensor with
Tracing output signal: 5V AC
Power supply: ±12V DC
Rated input current: 0-10mA AC

DIMENSIONS (mm)

Pin Arrangement

Pin	1	2	3	4
Function	V+	V-	OUT	GND

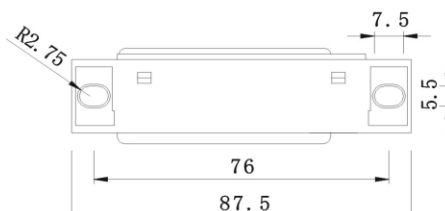
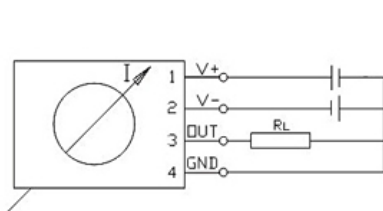
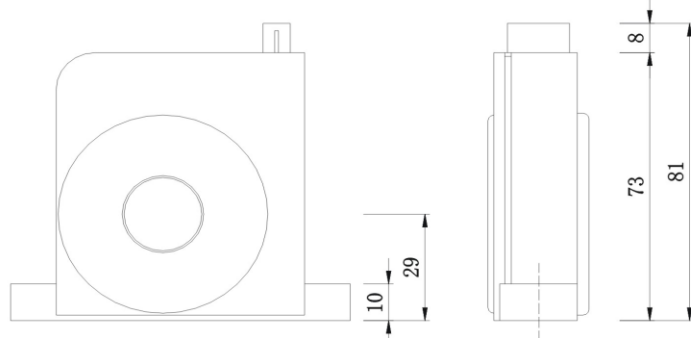
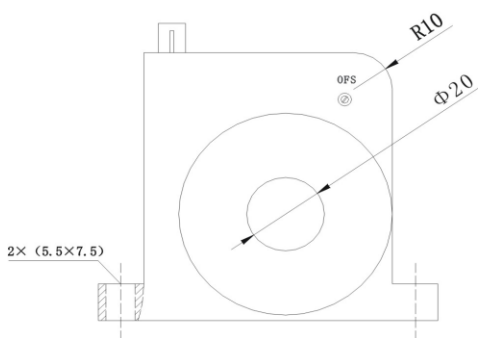
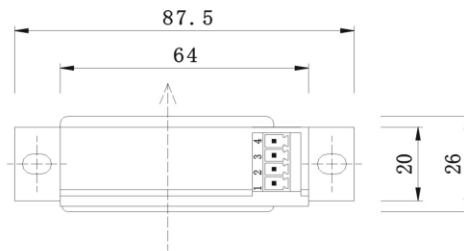

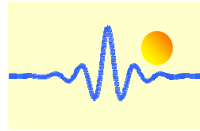

CONNECTION

The current carrying cable must pass through the window. The phase of output is the same as that of the current passing the window in the direction of the arrow indicated on the case.

- 1: V+ Power Supply
- 2: V- Power Supply
- 3: Output
- 4: Ground

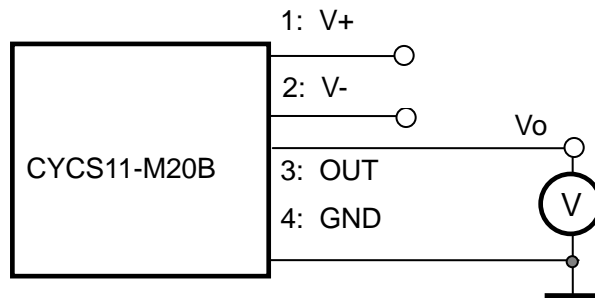

Relation between Input and Output:

Sensor CYCS11-36M20B-1.0-10mA		Sensor CYCS11-15M20B-1.0-10mA	
Input current (rms, mA)	Output voltage (rms, V)	Input current (mA)	Output voltage (V)
0	0	-10	-5
2.5	1.25	-5	-2.5
5	2.5	0	0
7.5	3.75	5	2.5
10	5	10	5

Notes:

1. Connect the terminals of power source, outputs respectively and correctly, never make wrong connection.
2. The potentiometer can be adjusted, only if necessary, by turning slowly to the required accuracy with a small screwdriver.
3. The best accuracy can be achieved when the window is fully filled with current carrying conductor
4. The in-phase output can be obtained when the direction of current of current carrying conductor is the same as the direction of arrow marked on the transducer case.