

Catalogue

Hall Effect Proximity Switches / Sensors

Copyright© 2012, ChenYang Technologies GmbH & Co. KG

All rights reserved. No part of this catalogue may be reproduced, stored in a retrieval system or transmitted in any form or by any means, electronic, mechanical, photocopying, recording or otherwise, without the prior permission of the copyright holder.

Contact Address:

Markt Schwabener Str. 8
D-85464 Finsing
Germany

Tel: +49 (0)8121-2574100
Fax: +49 (0)8121-2574101
Email: info@chenyang.de
<http://www.chenyang.de>

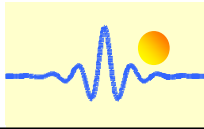

Contents

Hall Effect Proximity Switches	1
Hall Effect Proximity Switch CYKN8-02CL0.....	6
Hall Effect Proximity Switch CYKN8-02CL5.....	8
Hall Effect Proximity Switch CYKP8-02CL0.....	10
Hall Effect Proximity Switch CYKN8-20DL2.....	12
Hall Effect Proximity Switch CYBN8-20DL2.....	14
Hall Effect Proximity Switch CYKP8-20DL2.....	16
Hall Effect Proximity Switch CYBP8-20DL2.....	18

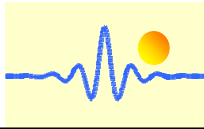

Hall Effect Proximity Switches

A Hall Effect proximity switch is a non-contact electronic switch, which consist of a permanent magnet or ferromagnetic part as trigger intermediary and a Hall Effect sensor IC. The Hall sensor IC detects the change of the magnet field when the permanent magnet comes in the close proximity to it and generates an electric signal. This signal is amplified and rectified to control the output signal of the switch.



Compared with magneto-electric, optoelectronic and capacitive proximity switches, Hall proximity switches have the advantages of good output wave shape, high stability, low costs, unaffected by oil, dirt and vibration, and wide operating temperature etc. They are very suitable for integrating in PC systems and various kinds of industrial control equipments, and are optimal switches for position control, speed measurement, counting, direction detection and automatic protection etc.

General Properties

Ambient temperature:	-25°C ~ +125°C	Ambient humidity:	35%~95%
Max. supply current:	≤ 25mA	Reverse supply voltage:	≤ -35V
Frequency range:	0~50KHz	Position repeatability:	0.02mm
Overcurrent indication:	Red LED	Sensing object:	Magnet S-pole
Max. output current:	20mA – 200mA	Power supply:	5 – 30V
Max. sensing distance:	8mm	Max. voltage drop:	0.4V – 1.0V
Isolation voltage:	AC 1500V, 50/60Hz, 1min	Case material:	Brass, chrome plated

Definition of Part number:

C	Y	K	N	8	—	20	B	L
(1)	(2)	(3)	(4)	(5)	(6)	(7)	(8)	

(1) (2)	(3)	(4)	(5)	(6)	(7)	(8)
Series name	Output type (1)	Output type (2)	Max. sensing distance	Max. output current	Power supply	Case style and number
CY	K: Open, single output B: Close, single output K/B: Open/Close double output Z: Magnetic Latching G/F: Counting/direction double output	N:NPN P:PNP	8: 8mm	02: 20mA 05: 50mA 20: 200mA	A: 5±0.25V B: 5 ~ 9V C: 4.5~24V D: 8 ~ 30V	L: Cylinder with screw B: block

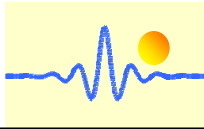

Output signal

Output voltage	Open output mode	Closed output mode
NPN Output		
PNP Output		

Part number

Part number	Output type	Max. voltage drop	Action indication	Output surge protection	Output short protection	Length of leads (M)**	Connection	Dimensions (mm)		
								Diameter	Screw pitch	Length
CYKN8-02CLO	OC	0.4V	no	no	no	0.5	Fig.1	M8	0.75	20
CYKP8-02CLO	OC	0.4V	no	no	no	0.5	Fig.4	M8	0.75	20
CYKN8-02CL1	OC	0.4V	no	no	no	0.5	Fig.1	M12	1	26
CYKN8-02CL5	RC	0.4V	Yes	no	no	0.5	Fig. 7	M10	1	35
CYKN8-05BL2	OC	0.4V	Yes	Yes	no	0.5	Fig. 1	M12	1	40
CYKN8-05DL2	OC	0.4V	Yes	Yes	no	0.5	Fig. 1	M12	1	40
CYKN8-20BL2	OC	1.0V	Yes	Yes	Yes	0.5	Fig. 1	M12	1	40
CYKN8-20DL2	OC	1.0V	Yes	Yes	Yes	0.5	Fig. 1	M12	1	40
CYBN8-20BL2	OC	1.0V	Yes	Yes	Yes	0.5	Fig. 2	M12	1	40
CYBN8-20DL2	OC	1.0V	Yes	Yes	Yes	0.5	Fig. 2	M12	1	40
CYKP8-20BL2	OC	1.0V	Yes	Yes	Yes	0.5	Fig. 4	M12	1	40
CYKP8-20DL2	OC	1.0V	Yes	Yes	Yes	0.5	Fig. 4	M12	1	40
CYBP8-20BL2	OC	1.0V	Yes	Yes	Yes	0.5	Fig. 5	M12	1	40
CYBP8-20DL2	OC	1.0V	Yes	Yes	Yes	0.5	Fig. 5	M12	1	40
CYK/BN8-20BL2	OC	1.0V	Yes	Yes	Yes	0.5	Fig. 3	M12	1	40
CYK/BN8-20DL2	OC	1.0V	Yes	Yes	Yes	0.5	Fig. 3	M12	1	40
CYK/BP8-20BL2	OC	1.0V	Yes	Yes	Yes	0.5	Fig. 6	M12	1	40
CYK/BP8-20DL2	OC	1.0V	Yes	Yes	Yes	0.5	Fig. 6	M12	1	40
CYZN8-02CLO	OC	0.4V	no	no	no	0.5	Fig. 1	M8	0.75	20
CYZN8-02CL1	OC	0.4V	no	no	no	0.5	Fig. 1	M12	1	26
CYZN8-05BL2	OC	0.4V	Yes	Yes	no	0.5	Fig. 1	M12	1	40
CYZN8-05DL2	OC	0.4V	Yes	Yes	no	0.5	Fig. 1	M12	1	40
CYZN8-20BL2	OC	1.0V	Yes	Yes	Yes	0.5	Fig. 1	M12	1	40
CYZN8-20DL2	OC	1.0V	Yes	Yes	Yes	0.5	Fig. 1	M12	1	40
CYZP8-20BL2	OC	1.0V	Yes	Yes	Yes	0.5	Fig. 3	M12	1	40
CYZP8-20DL2	OC	1.0V	Yes	Yes	Yes	0.5	Fig. 3	M12	1	40
CYG/FN8-05AL3	RC	0.4V	Yes	no	no	0.5	Fig. 8	M18	1	40
CYG/FN8-05DL3	RC	0.4V	Yes	no	no	0.5	Fig. 8	M18	1	40

** : Length of leads: standard 0.5m, maximum length 20m

OC: Output transistor without any inner connected resistor. An outer resistor must be connected to the output for applications.

RC: An inner resistor is connected to the output transistor. The output signal can be connected to digital circuits and microprocessors directly.

Operation Point (Gauss)			Release Point (Gauss)			Hysteresis (Gauss)		
Min	typ.	Max	Min	typ.	Max	Min	typ.	Max
70	200	350	50	140	330	20	60	80

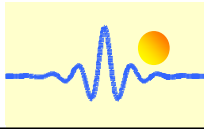

Connection

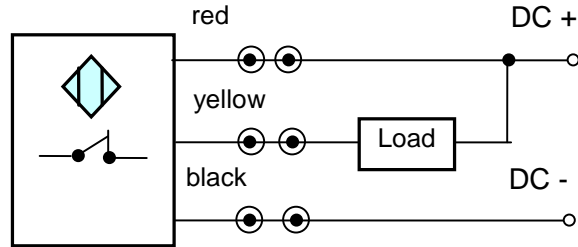

Fig. 1



Fig. 2

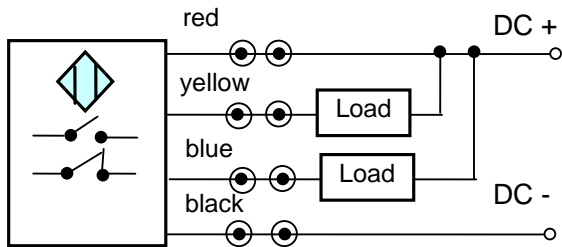

Fig. 3

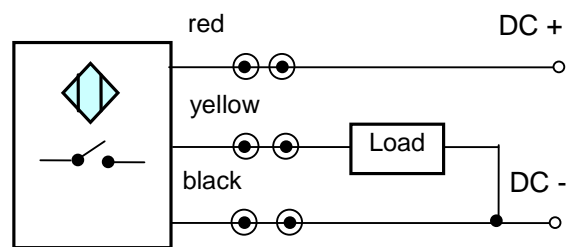

Fig. 4

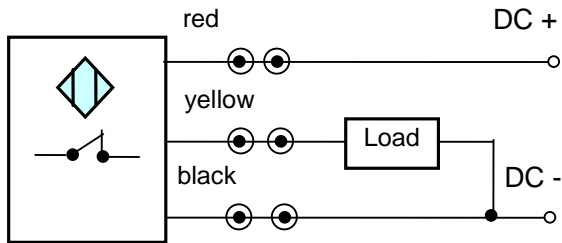

Fig. 5

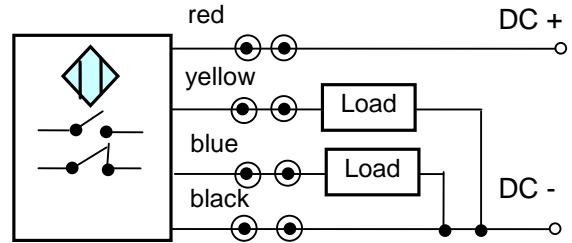

Fig. 6

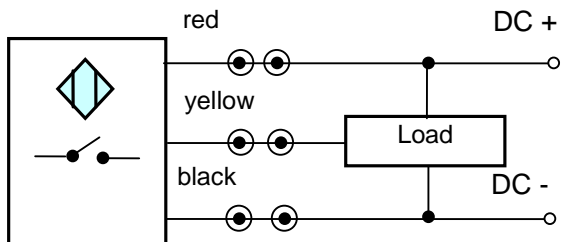

Fig. 7(*1)

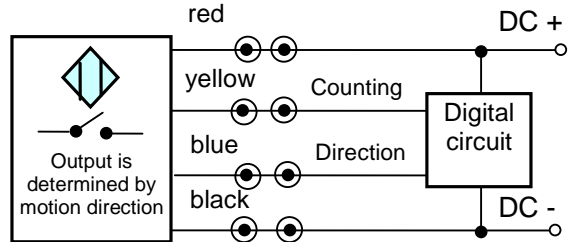
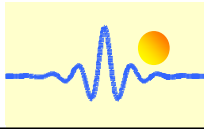

Fig. 8(*2)

*1: Option: load connection according to Fig. 1

*2: Option: load connection according to Fig. 3



Mounting Dimensions



L0



L1



L2



L2



L5

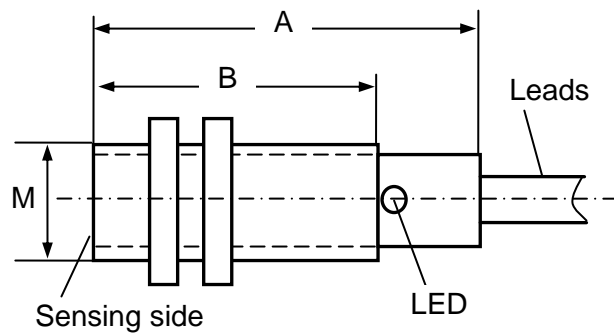

Case Style	L0	L1	L2	L5
A (mm)	20	26	40	35
B (mm)	15	20	30	26
M (mm)	M8 x 0.75	M12 x 1	M12 x 1	M10 x 1

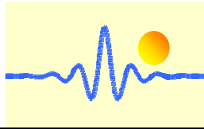

Application Notes

1) Application Methods

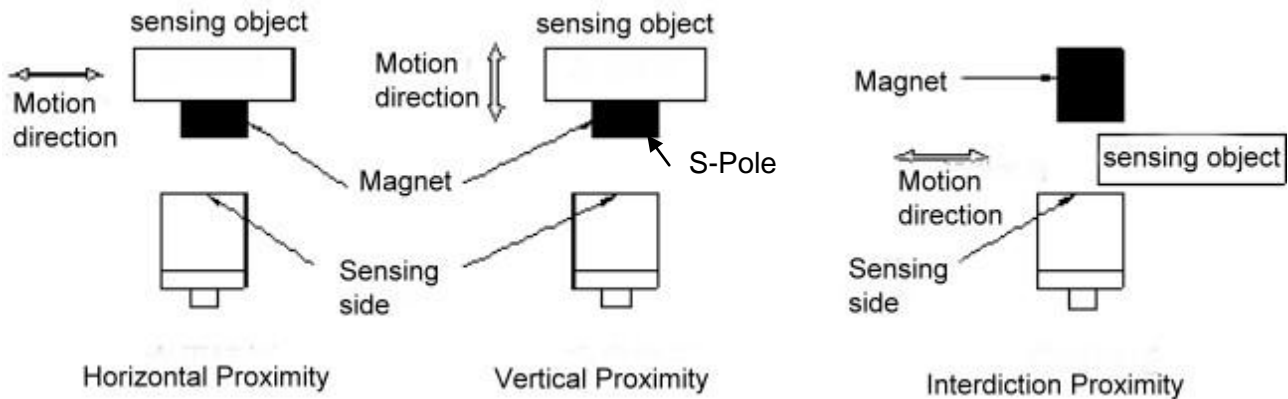

S-Pole is arranged to the sensing side of the sensor

2) Magnets

The magnets can be selected according to the maximum sensing distance. The following table show some standard NdFeB and SmCo magnets for the applications.

SmCo Magnets (maximum working temperature: 250°C – 350°C)

Type	Dimensions	Type	Dimensions	Type	Dimensions	Type	Dimensions
B1-S	4x3.3x(1.5)	B4-S	4.5x4.5x(4)	D8-S	Φ8x(3.5)	D15-S	Φ15x(6)
B2-S	5x4x(2.2)	D3-S	Φ3x(5)	D10-S	Φ10x(6)	D18-S	Φ18x(8)
B3-S	5x5x(2.5)	D6-S	Φ6x(3.5)	D12-S	Φ12x(4)		

NdFeB Magnets (maximum working temperature: 80°C – 200°C)

Type	Dimensions	Type	Dimensions	Type	Dimensions	Type	Dimensions
B1-N	4x3.3x(1.5)	B4-N	4.5x4.5x(4)	D8-N	Φ8x(3.5)	D15-N	Φ15x(6)
B2-N	5x4x(2.2)	D3-N	Φ3x(5)	D10-N	Φ10x(6)	D18-N	Φ18x(8)
B3-N	5x5x(2.5)	D6-N	Φ6x(3.5)	D12-N	Φ12x(4)		

Magnetization direction: in height direction (dimension in bracket)

Maximum sensing distance of magnets (T=25°C)

Magnet type (N or S)	B1	B2	B3	B4	D3	D6	D8	D10	D12	D15	D18
Sensing distance (mm)	3.0	4.0	5.0	6.0	3.0	7.0	9.0	12.0	12.0	16.0	20.0

For further info visit please website: <http://www.cy-magnetics.com>

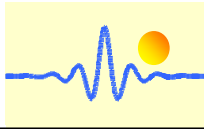

Hall Effect Proximity Switch CYKN8-02CL0

General Properties

Ambient temperature:	-25°C ~ +125°C	Ambient humidity:	35%~95%
Max. supply current:	≤ 25mA	Reverse supply voltage:	≤ -35V
Frequency range:	0~50KHz	Position repeatability:	0.02mm
Overcurrent indication:	Red LED	Sensing object:	Magnet S-pole
Max. output current:	20mA	Power supply:	4.5 – 24V
Max. sensing distance:	8mm	Max. voltage drop:	0.4V
Output type	OC, NPN, open single	Case material:	Brass, chrome plated
Isolation voltage:	AC 1500V, 50/60Hz,1min	Cylinder with Screw	M8 x0.75

OC: Output transistor without any inner connected resistor. An outer resistor must be connected to the output for applications.

Operation Point (Gauss)			Release Point (Gauss)			Hysteresis (Gauss)		
Min	typ.	Max	Min	typ.	Max	Min	typ.	Max
70	200	350	50	140	330	20	60	80

Connection

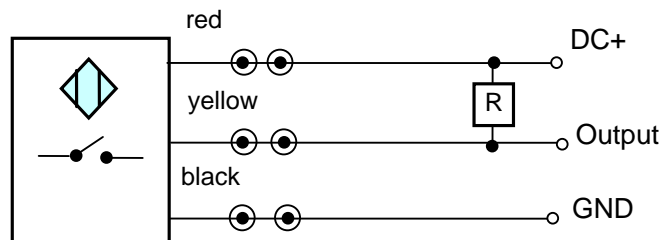

R: Pull-up resistor, 1k ~ 10k, normally 2k~3k

Mounting Dimensions



Diameter	Screw pitch	Length	Length of leads
M8	0.75	20	650mm

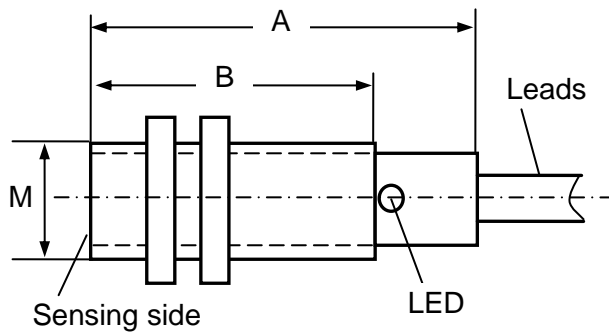
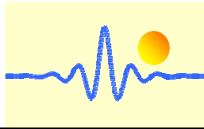

Case Style	L0
A (mm)	20
B (mm)	15
M (mm)	M8 x 0.75

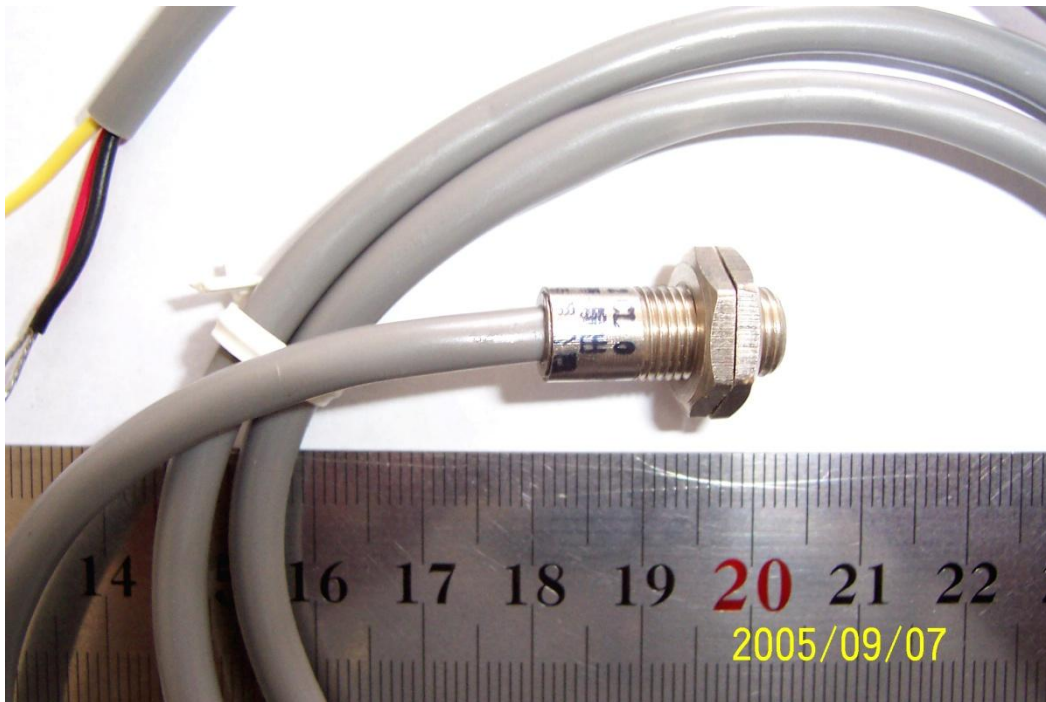

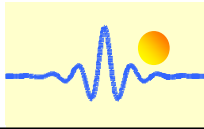

Hall Effect Proximity Switch CYKN8-02CL5

General Properties

Ambient temperature:	-25°C ~ +125°C	Ambient humidity:	35%~95%
Max. supply current:	≤ 25mA	Reverse supply voltage:	≤ -35V
Frequency range:	0~50KHz	Position repeatability:	0.02mm
Overcurrent indication:	Red LED	Sensing object:	Magnet S-pole
Max. output current:	20mA	Power supply:	4.5– 24V DC
Max. sensing distance:	8mm	Max. voltage drop:	1.0V
Output type	OC, NPN, open single	Case material:	Brass, chrome plated
Isolation voltage:	AC 1500V, 50/60Hz,1min	Cylinder with Screw	M10 x 1, length: 35mm
Action indication	Yes	Output surge protection	No
Output short protection	No		

OC: Output transistor without any inner connected resistor. An outer resistor must be connected to the output for applications.

Operation Point (Gauss)			Release Point (Gauss)			Hysteresis (Gauss)		
Min	typ.	Max	Min	typ.	Max	Min	typ.	Max
70	200	350	50	140	330	20	60	80

Connection

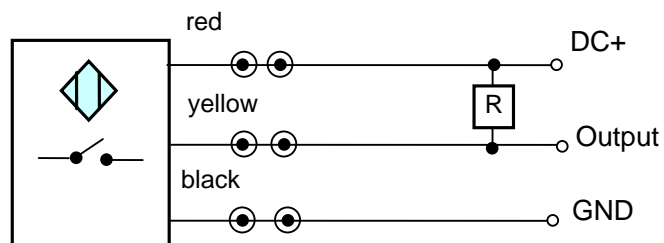

R: Pull-up resistor, 1k ~ 10k, normally 2k~3k

Mounting Dimensions



Diameter	Screw pitch (mm)	Length (mm)	Length of leads (m)
M10	1.0	35	2.0 max 0.5 Typical

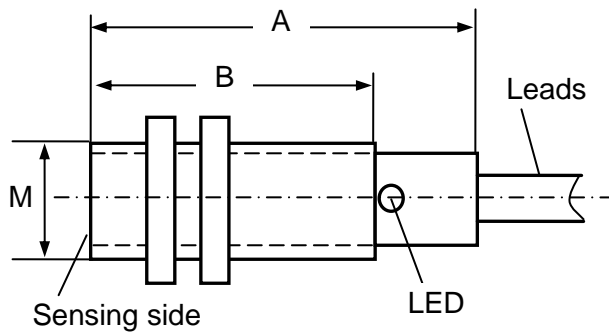
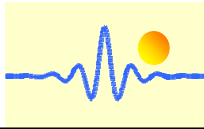

Case Style	L2
A (mm)	35
B (mm)	26
M (mm)	M10 x 1



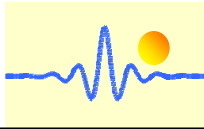

Hall Effect Proximity Switch CYKP8-02CL0

General Properties

Ambient temperature:	-25°C ~ +125°C	Ambient humidity:	35%~95%
Max. supply current:	≤ 25mA	Reverse supply voltage:	≤ -35V
Frequency range:	0~50KHz	Position repeatability:	0.02mm
Overcurrent indication:	Red LED	Sensing object:	Magnet S-pole
Max. output current:	20mA	Power supply:	4.5 – 24V
Max. sensing distance:	8mm	Max. voltage drop:	0.4V
Output type	OC, PNP, open single	Case material:	Brass, chrome plated
Isolation voltage:	AC 1500V, 50/60Hz, 1min	Cylinder with Screw	M8 x0.75

OC: Output transistor without any inner connected resistor. An outer resistor must be connected to the output for applications.

Operation Point (Gauss)			Release Point (Gauss)			Hysteresis (Gauss)		
Min	typ.	Max	Min	typ.	Max	Min	typ.	Max
70	200	350	50	140	330	20	60	80

Connection

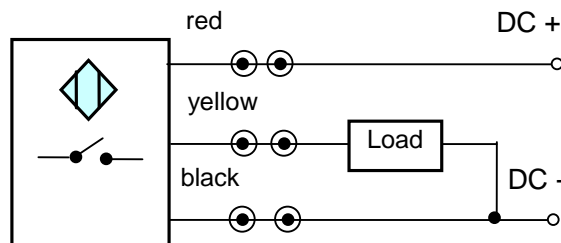

R: Pull-up resistor, 1k ~ 10k, normally 2k~3k

Mounting Dimensions



Diameter	Screw pitch	Length	Length of leads
M8	0.75	20mm	650mm

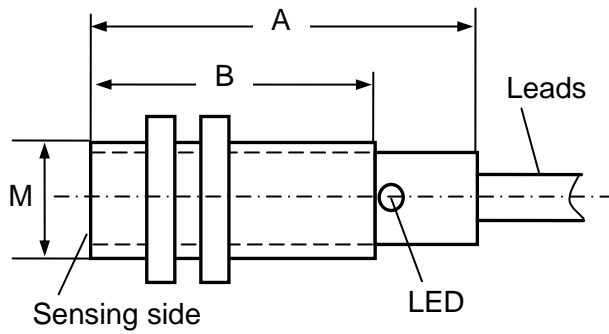
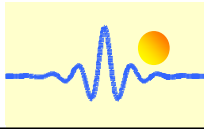

Case Style	L0
A (mm)	20
B (mm)	15
M (mm)	M8 x 0.75

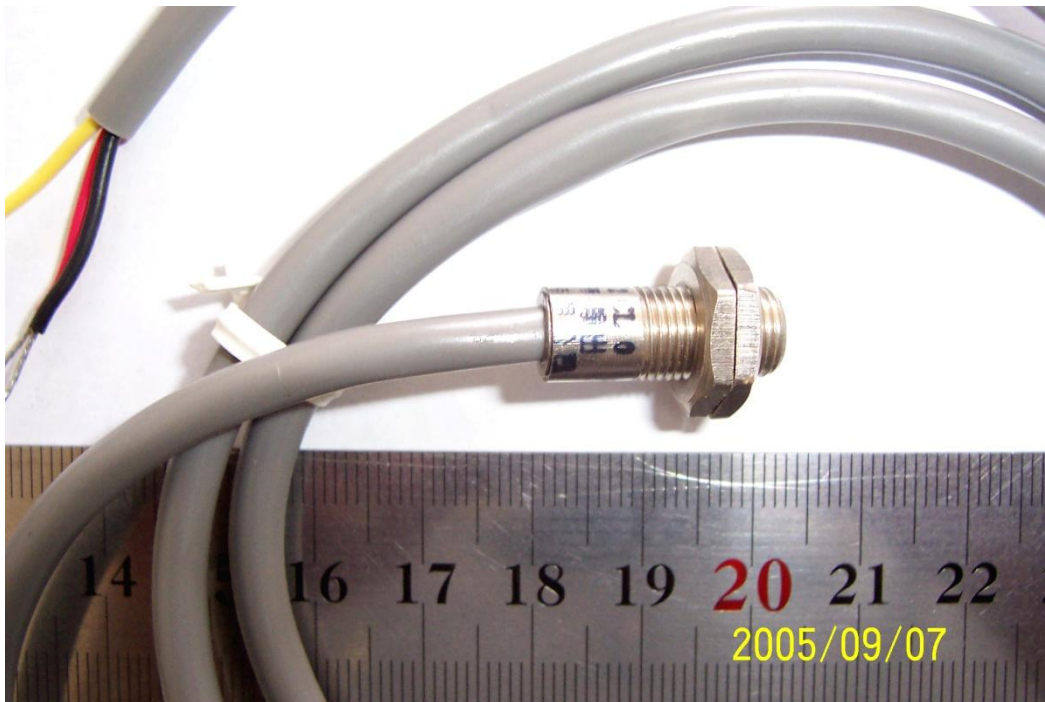

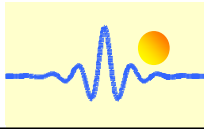

Hall Effect Proximity Switch CYKN8-20DL2

General Properties

Ambient temperature:	-40°C ~ +125°C	Ambient humidity:	35%~95%
Max. supply current:	≤ 25mA	Reverse supply voltage:	≤ -35V
Frequency range:	0~50KHz	Position repeatability:	0.02mm
Overcurrent indication:	Red LED	Sensing object:	Magnet S-pole
Max. output current:	200mA	Power supply:	8 – 30V
Max. sensing distance:	8mm	Max. voltage drop:	1.0V
Output type	OC, NPN, open single	Case material:	Brass, chrome plated
Isolation voltage:	AC 1500V, 50/60Hz, 1min	Cylinder with Screw	M12 x 1, length: 40mm
Action indication	Yes	Output surge protection	Yes
Output short protection	Yes		

OC: Output transistor without any inner connected resistor. An outer resistor must be connected to the output for applications.

Operation Point (Gauss)			Release Point (Gauss)			Hysteresis (Gauss)		
Min	typ.	Max	Min	typ.	Max	Min	typ.	Max
70	200	350	50	140	330	20	60	80

Connection

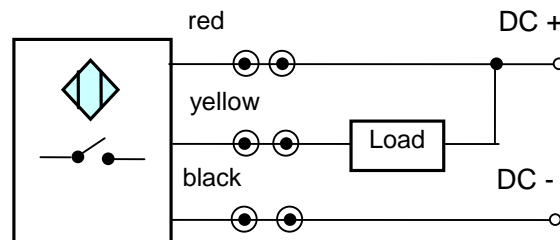

R: Pull-up resistor, 1k ~ 10k, normally 2k~3k

Mounting Dimensions

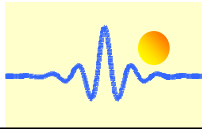

Diameter	Screw pitch (mm)	Length (mm)	Length of leads (m)
M12	1.0	40	2.0 max 0.5 Typical

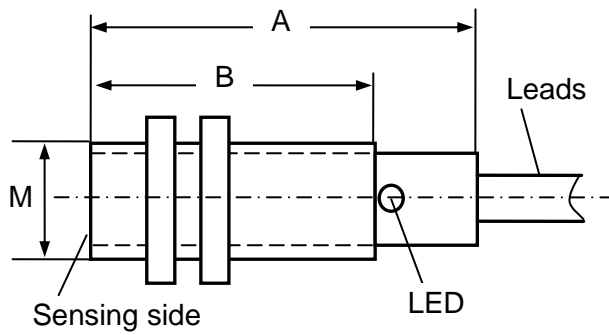

Case Style	L2
A (mm)	40
B (mm)	30
M (mm)	M12 x 1



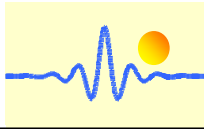

Hall Effect Proximity Switch CYBN8-20DL2

General Properties

Ambient temperature:	-25°C ~ +125°C	Ambient humidity:	35%~95%
Max. supply current:	≤ 25mA	Reverse supply voltage:	≤ -35V
Frequency range:	0~50KHz	Position repeatability:	0.02mm
Overcurrent indication:	Red LED	Sensing object:	Magnet S-pole
Max. output current:	200mA	Power supply:	8 – 30V
Max. sensing distance:	8mm	Max. voltage drop:	1.0V
Output type	OC, NPN, closed single	Case material:	Brass, chrome plated
Isolation voltage:	AC 1500V, 50/60Hz, 1min	Cylinder with Screw	M12 x 1, length: 40mm
Action indication	Yes	Output surge protection	Yes
Output short protection	Yes		

OC: Output transistor without any inner connected resistor. An outer resistor must be connected to the output for applications.

Operation Point (Gauss)			Release Point (Gauss)			Hysteresis (Gauss)		
Min	typ.	Max	Min	typ.	Max	Min	typ.	Max
70	200	350	50	140	330	20	60	80

Connection

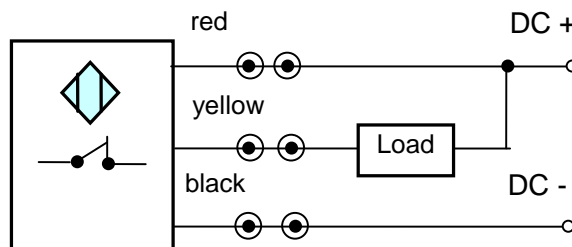

R: Pull-up resistor, 1k ~ 10k, normally 2k~3k

Mounting Dimensions

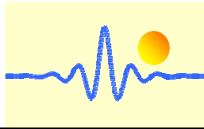

Diameter	Screw pitch (mm)	Length (mm)	Length of leads (m)
M12	1.0	40	2.0 max 0.5 Typical

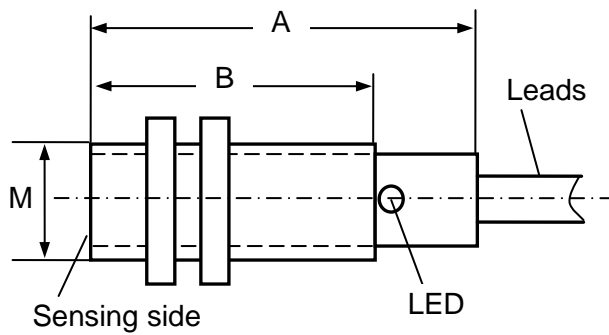

Case Style	L2
A (mm)	40
B (mm)	30
M (mm)	M12 x 1



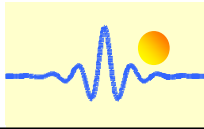

Hall Effect Proximity Switch CYKP8-20DL2

General Properties

Ambient temperature:	-25°C ~ +125°C	Ambient humidity:	35%~95%
Max. supply current:	≤ 25mA	Reverse supply voltage:	≤ -35V
Frequency range:	0~50KHz	Position repeatability:	0.02mm
Overcurrent indication:	Red LED	Sensing object:	Magnet S-pole
Max. output current:	200mA	Power supply:	8 – 30V
Max. sensing distance:	8mm	Max. voltage drop:	1.0V
Output type	OC, PNP, open single	Case material:	Brass, chrome plated
Isolation voltage:	AC 1500V, 50/60Hz, 1min	Cylinder with Screw	M12 x 1, length: 40mm
Action indication	Yes	Output surge protection	Yes
Output short protection	Yes		

OC: Output transistor without any inner connected resistor. An outer resistor must be connected to the output for applications.

Operation Point (Gauss)			Release Point (Gauss)			Hysteresis (Gauss)		
Min	typ.	Max	Min	typ.	Max	Min	typ.	Max
70	200	350	50	140	330	20	60	80

Connection

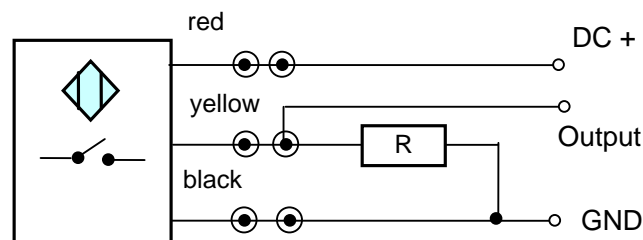

R: Pull-up resistor, 1k ~ 10k, normally 2k~3k

Mounting Dimensions

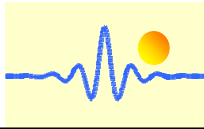

Diameter	Screw pitch (mm)	Length (mm)	Length of leads (m)
M12	1.0	40	2.0 max 0.5 Typical

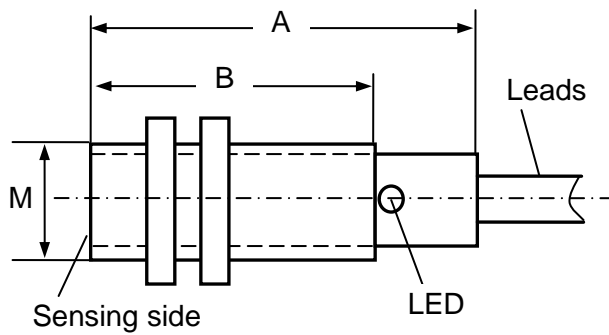

Case Style	L2
A (mm)	40
B (mm)	30
M (mm)	M12 x 1



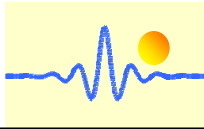

Hall Effect Proximity Switch CYBP8-20DL2

General Properties

Ambient temperature:	-25°C ~ +125°C	Ambient humidity:	35%~95%
Max. supply current:	≤ 25mA	Reverse supply voltage:	≤ -35V
Frequency range:	0~50KHz	Position repeatability:	0.02mm
Overcurrent indication:	Red LED	Sensing object:	Magnet S-pole
Max. output current:	200mA	Power supply:	8 – 30V
Max. sensing distance:	8mm	Max. voltage drop:	1.0V
Output type	OC, PNP, closed single	Case material:	Brass, chrome plated
Isolation voltage:	AC 1500V, 50/60Hz, 1min	Cylinder with Screw	M12 x 1, length: 40mm
Action indication	Yes	Output surge protection	Yes
Output short protection	Yes		

OC: Output transistor without any inner connected resistor. An outer resistor must be connected to the output for applications.

Operation Point (Gauss)			Release Point (Gauss)			Hysteresis (Gauss)		
Min	typ.	Max	Min	typ.	Max	Min	typ.	Max
70	200	350	50	140	330	20	60	80

Connection

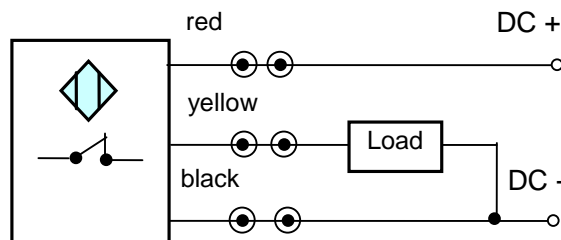

R: Pull-up resistor, 1k ~ 10k, normally 2k~3k

Mounting Dimensions

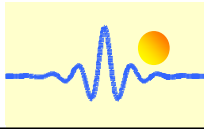

Diameter	Screw pitch (mm)	Length (mm)	Length of leads (m)
M12	1.0	40	2.0 max 0.5 Typical

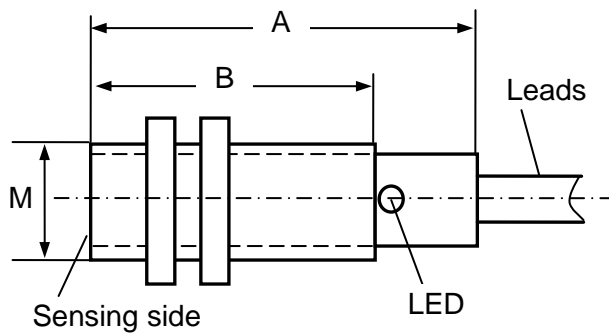

Case Style	L2
A (mm)	40
B (mm)	30
M (mm)	M12 x 1

